

Window installation instructions



Part NO. YW40

July 2021

WHERE WINDOWS ARE JUST THE BEGINNING®



TABLE OF CONTENTS

General Overview

1. General notes
2. Construction notes
3. Building codes
4. Condition inspection and preparation
5. Perimeter anchorage
6. Vent inspection or reinstallation

Basic Installation Without Subframe or Panning

1. Installation of window units in masonry openings
2. Installation with optional "F" anchors clips
3. Installation of architectural sills
4. Installation of gravity anchors
5. Installation of side stack systems
6. Installation of mullions when not using Subframe or Panning
7. Installation of optional frame extenders

Hung Window Installation

1. General notes
2. Tilt window sash removal and cleaning instructions
3. Tilt window balance removal and installation
4. Side load sash - balance removal for block and tackle balances
5. Side load sash - balance removal for Class 5 balances (third generation carrier)

Sliding Window Sash Removal

1. General notes

Casement Window Installation

1. General notes

Pivot Window Installation

1. General notes

Panning Frame Installation

1. General notes
2. Mullion installation into panning

Subframe Installation

1. General notes
2. Mullion Installation into subframe

Subframe with Integral Vapor Barrier Installation

1. General notes

Screen Frame Installation

1. Project-In screen installation
2. Project-Out screen installation
3. Project-Out casement installation
4. Single hung screen installation
5. Double hung screen installation
6. Horizontal sliding window screen installation
7. Interior vertical sliding screen installation

Minimizing Condensation

Note: Please reference EFCO's "Understanding Condensation" brochure which can be obtained through your EFCO representative.

Condensation will form on any surface when unfavorable conditions (interior temperature and relative humidity and exterior temperature) are present. When the formation of excessive condensation is a concern, it is highly recommended that a design professional is utilized to perform an analysis of the shop drawings to recommend the best possible installation methods. Please contact your EFCO representative for information on EFCO's Thermal Analysis Services.

Many current installation practices lead to an increase in the possibility of the formation of condensation. Though not all inclusive, the list of examples below illustrates conditions under which condensation is likely to occur:

1. Bridging system thermal break with non-thermally broken metal flashing or lintels that are exposed to the exterior
2. System exposure to cold air cavities
3. Interior relative humidity levels not maintained at recommended levels, see EFCO's "Understanding Condensation" brochure
4. Inadequate separation between system and surrounding condition at perimeter
5. Product combinations during the shop drawing stage that result in bridging thermal breaks
of one or all products involved

These recommendations are for general erection procedures only. For actual job conditions, see the details on the shop drawings. For perimeter anchor type and spacing, refer to the approved shop drawings or consult the project design professional.

1. General notes

Windows are finished products and must be protected against damage. The following procedures and precautions are recommended:

A. Protection and Storage

1. Handle the material carefully.
2. Do not drop or drag from the truck to avoid racking or damage to windows or accessories.
3. Stack the windows with the directional arrows in the proper position, and allow adequate separation so the windows will not rub together.
4. Store the windows off the ground (i.e., pallets, planks, etc.).
5. Protect against the elements and other construction trades by using a well ventilated covering.
6. Remove material from packaging if it becomes wet. Then repack materials and move to a dry location.
7. Caution: Windows are not to be used as ladders, scaffolds, or scaffold supports.

B. Check Material

1. Check all the material upon arrival for quantity and damage. Any visibly damaged material must be noted on the freight bill at the time of receipt. If a claim is required, the receiving party must process a claim with the freight carrier. If the delivery is by an EFCO truck, any damage or variance in the quantity of window units or boxes must be reported to the EFCO driver during the unloading process.

C. Cleaning Window Units

1. Cement, plaster, terrazzo, alkaline, and acid based materials used to clean masonry are very harmful to finishes and should be removed with water and mild soap immediately; otherwise, permanent staining will occur. A spot test is recommended before any cleaning agent is used.
2. For cleaning of anodized aluminum surfaces, refer to AAMA 609.1-85 Voluntary Guide Specification for Cleaning and Maintenance of Architectural Anodized Aluminum.
3. For cleaning of painted aluminum surfaces, refer to AAMA 610.79 Voluntary Guide Specification for Cleaning and Maintenance of Painted Aluminum Extrusions and Curtain Wall Panels.

Please note: The prolonged application of masking tape, duct tape, and similar products to painted aluminum surfaces will induce permanent bonding of the tape to the paint. This will cause adhesion failure between the paint and the aluminum surface when the tape is removed.

4. If a protective coating is specified, remove it from areas that require field applied sealants prior to installation.

These recommendations are for general erection procedures only. For actual job conditions, see the details on the shop drawings. For perimeter anchor type and spacing, refer to the approved shop drawings or consult the project design professional.

2. Ship Open For Field Glazing

The following procedures are standard practice for EFCO corporation:

- A. For all ship open window lites, EFCO will provide glazing beads, bead vinyl, and setting blocks, based upon customers noted nominal thickness and the assumption that customer will glaze in a similar manor as EFCO standard in house practices.

(With only a few exceptions most of EFCO window products are wet glazed with a silicone sealant between the glazing leg and glass.)

Account Representatives or Account Managers are requested to advise the customers of this policy in writing during the review process.

- B. Customer should also understand that EFCO will not supply glazing sealants. Setting blocks will be ship in bulk with sizes based on our standard in house practices. Adjustments to block sizes due to variations in glass size are not the responsibility of EFCO for ship open applications.
- C. Customers that advise EFCO that they will be tape glazing must advise us of their actual glass thickness and dimensional allowance for tape and cap bead for appropriate bead and vinyl to be supplied. EFCO will not size for tape glazing without appropriate information. EFCO will not supply glazing tape or sealant for tape glazed method. Additional time and cost may be associated with tape glazing.

3. Construction notes

The following practices are recommended for all window installations:

A. Reference Shop Drawings

1. Check the shop drawings and installation instructions to become thoroughly familiar with the project. The shop drawings take precedence and include specific details for the project. The installation instructions are general in nature and cover the most common conditions.

B. Check Openings

1. Make certain that construction which will receive the material is in accordance with the contract documents. If not, notify the general contractor in writing and resolve differences before proceeding with your work.

C. Benchmark Layout

1. All work should start from benchmarks and/or column centers lines as established by the architectural drawings and the general contractor.

These recommendations are for general erection procedures only. For actual job conditions, see the details on the shop drawings. For perimeter anchor type and spacing, refer to the approved shop drawings or consult the project design professional.

D. Plumb / Level / True

1. All materials are to be installed plumb, level, true, and in proper alignment and relation to established line grades. Products are to be installed maintaining tolerances of 1/8" in 12'-0" of length.

E. Isolate Aluminum

1. Isolate aluminum that directly contacts masonry or incompatible materials with a heavy coat of zinc chromate, plastic isolators, or bituminous paint.

F. Poured and Debridged and Thermal Strut Sections

1. Do not drill, punch, penetrate, or alter the poured and debridged thermal break or extruded thermal strut in any manner.

G. Fastening

1. Fastening means any method of securing one part to another or to adjacent materials. Due to varying opening conditions, window configurations, design pressures, and methods of anchorage (subframe, "F" anchors, etc.), perimeter fasteners are not specified in these instructions. For anchor fastening, refer to the shop drawings or consult the project design professional.

Do not fasten drapery tracks, ceiling supports, or convector covers to windows. The window must be free to expand and contract.

H. Blocking

1. All blocking and shims will be high strength plastic or non-corrosive materials Not by EFCO. Blocking must be of sufficient size and shape to support the frame at all anchorage locations. The blocking must prevent the anchorage fasteners from bowing, racking, twisting, or distorting the window frames and accessories in any manner.

I. Sealant

1. Sealants must be compatible with all materials they contact, including other sealant surfaces. Any sealant details shown herein, unless specifically called out to be by EFCO, are by others.
2. It is not EFCO Corporation's position to select or recommend sealant or caulking types and will not assume liability or responsibility thereof. Consult the sealant supplier for recommendations relative to compatibility, adhesion, priming, tooling, shelf life, and joint design. It is the sole responsibility of the customer to perform all sealant adhesion and compatibility testing that is required by the sealant manufacturer of choice.
3. Seal all exposed perimeter joints between structure and window perimeters along with all window to window and window to accessory (subframe, panning, mullions) joints. Seal all anchor heads along the sill and 6" up the jambs. Refer to the approved shop drawings for joint design.

These recommendations are for general erection procedures only. For actual job conditions, see the details on the shop drawings. For perimeter anchor type and spacing, refer to the approved shop drawings or consult the project design professional.

4. Building Codes

Glass and glazing codes governing the design and use of products vary widely. EFCO does not control the selection of product configurations, operating hardware, or glazing materials; therefore, we assume no responsibility in these areas. It is the responsibility of the owner, architect, and the installer to make these selections in strict conformity to all applicable codes.

5. Condition Inspection and Preparation

- A. The rough opening should be checked for the correct size as determined by tolerances listed in the architectural specifications and the shop drawings.
- B. Establish the face of the window line at the head, sill, and jambs. This reference is arrived at by using the architectural plans, general contractor's reference lines, and shop drawings.
- C. Determine the high point of the masonry sill using a string line or transit and shim the balance of the opening to match.

Note: For proper vent operation and drainage of windows, they must be installed plumb & level.

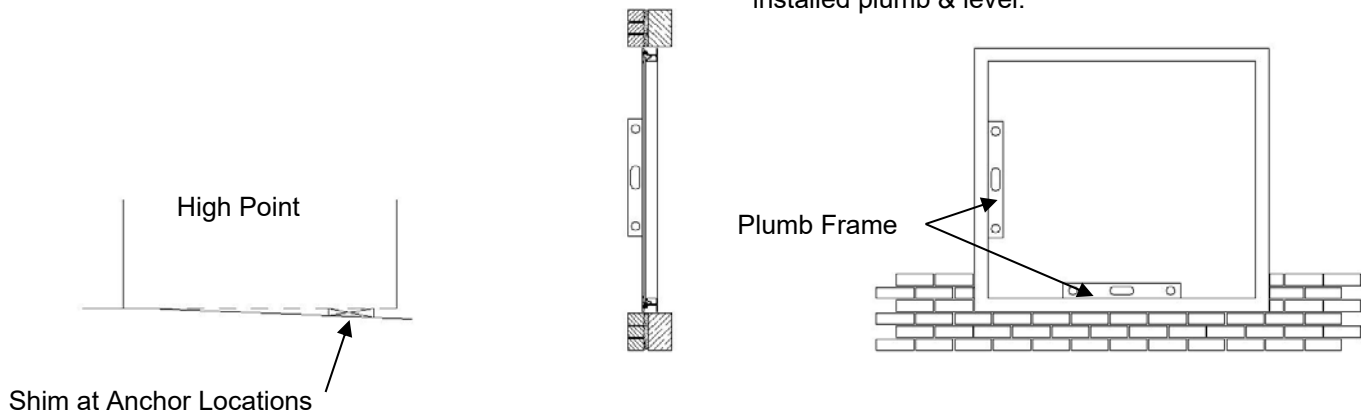

These recommendations are for general erection procedures only. For actual job conditions, see the details on the shop drawings. For perimeter anchor type and spacing, refer to the approved shop drawings or consult the project design professional.

6. Perimeter Anchorage

- A. From the approved shop drawings, determine the size, type, and quantity of perimeter fasteners required. EFCO will provide fasteners for EFCO material to EFCO material only. All perimeter fasteners are Not by EFCO and should be purchased prior to arriving at the job site. (If Subframe is used, please refer to the Subframe installation sheets.)

Due to varying opening conditions, window configurations, design pressures, and methods of anchorage (subframe, "F" anchors, etc.), perimeter fasteners are not specified in these instructions. For perimeter anchor type and spacing, refer to the approved shop drawings or consult the project design professional. The design professional should analyze the anchorage system, and take into account the following information.

1. Frame dimensions and configuration of the as-installed window.
2. Material properties of the window frame.
3. Allowable tension, shear, and bending properties of the perimeter fastener.
4. Design pressure.
5. Details of the surrounding condition for the head, sill, and jambs.
6. Relative building movements and expected thermal movement of the window system.

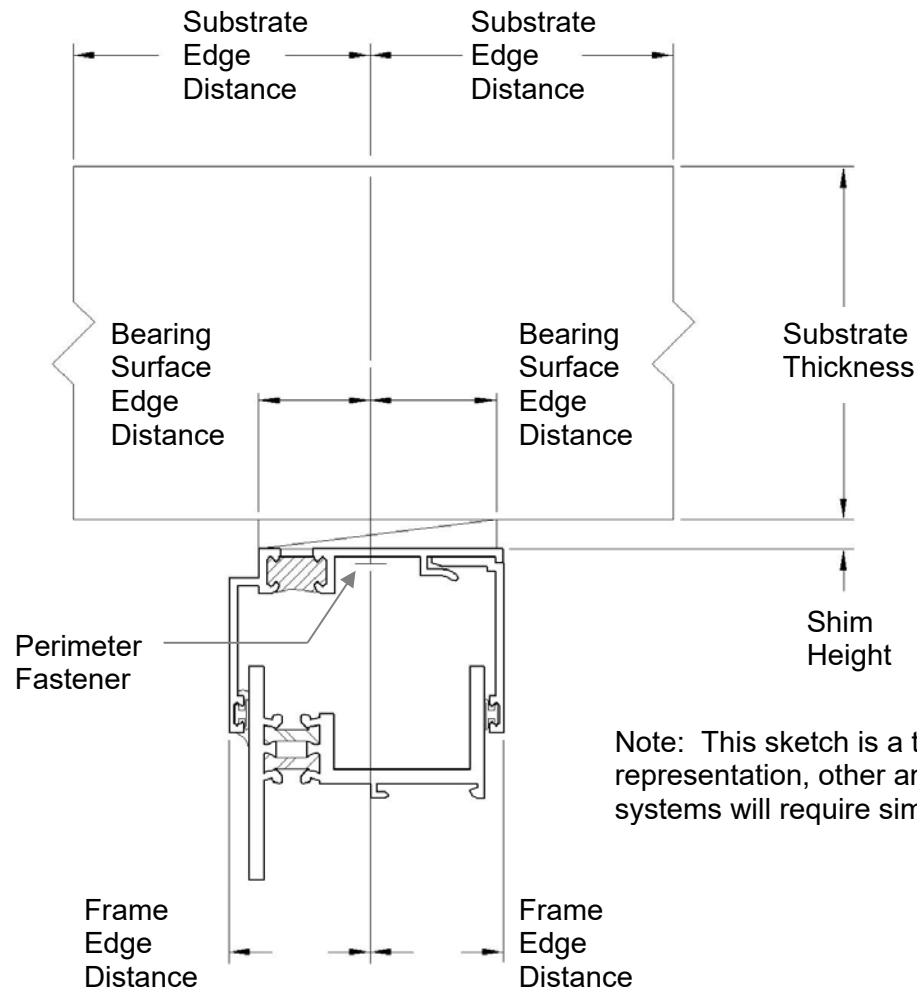

These recommendations are for general erection procedures only. For actual job conditions, see the details on the shop drawings. For perimeter anchor type and spacing, refer to the approved shop drawings or consult the project design professional.

- B. Perimeter anchors should never penetrate a tank or tubular shape at a window sill. Any penetration of the frame must be visible for sealing purposes.
- C. Blocking must be of sufficient size and shape to support the frame at all anchorage locations. The blocking must prevent the anchorage fasteners from bowing, racking, twisting, or distorting the window frames and accessories in any manner. Excessive shim heights could increase the prying tension and/or bending forces on the perimeter fastener. Refer to the approved shop drawings and/or design professional for project specific applications.

7. Vent Inspection or Reinstallation

- A. Upon completion of the window installation, all operating vents must be checked for proper alignment and operation. All hardware must be cleaned and lubricated as necessary to provide smooth operation.
- B. If the vents are removed, care must be taken to ensure the vents are reinstalled into the same frames they were removed from. It may be necessary to adjust the hinges, keepers, deflection stops, and friction arms to ensure proper sealing and locking.

Completely read the General Installation Instructions and all other sections which pertain to your project before starting work. These recommendations are for general erection procedures only. For actual job conditions, see the details on the shop drawings. For perimeter anchor types and spacing, refer to the approved shop drawings or consult the project design professional.

General Procedure for the Installation of Window Units in Masonry Openings Without Subframe or Panning

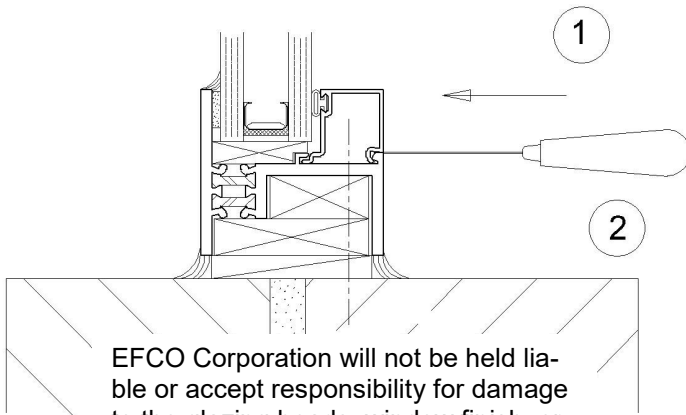

EFCO Corporation will not be held liable or accept responsibility for damage to the glazing beads, window finish, or broken glass, which is a result of this type of installation.

The glazing bead may require removal and reinstallation. Care must be exercised to avoid damaging the glazing beads. (Always remove beads that run between first).

To remove the glazing bead, apply pressure to the inside lower bead edge and compress the glazing vinyl. (See arrow one). While maintaining pressure, give a slight upward movement. If the bead is really tight, it may be necessary to insert a putty knife in the crevice between the bead and frame giving a slight twisting motion as pressure is applied to the bead.

Drilling of frame and blocking by erector. Field notching of glazing beads may be required to clear fastener heads before reinstallation of beads.

SYMBOLS LEGEND	
◇	INDICATES ANCHOR FASTENER BY THE ERECTOR
Ⓢ	INDICATES FIELD APPLIED SEALANT (NOT BY EFCO)
ⓑ	INDICATES BLOCKING BY THE ERECTOR
Ⓞ	INDICATES DRILLING BY THE ERECTOR

Optional PVC Frame Filler

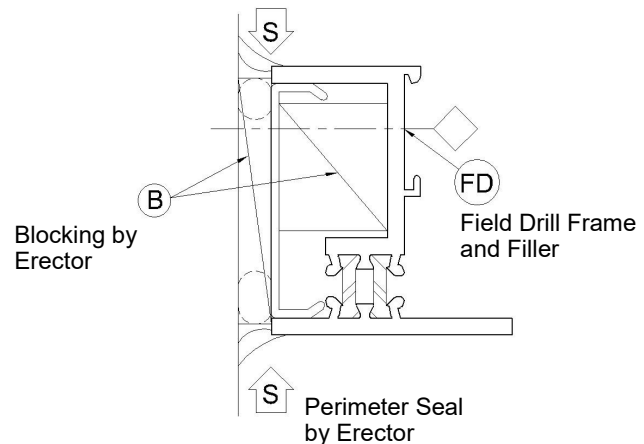

Completely read the General Installation Instructions and all other sections which pertain to your project before starting work. These recommendations are for general erection procedures only. For actual job conditions, see the details on the shop drawings. For perimeter anchor types and spacing, refer to the approved shop drawings or consult the project design professional.

Installation with Optional “F” Anchor Clips

1. Locate the “F” anchor clips around the entire window perimeter positioned as noted on the shop drawings and or anchorage calculations by the responsible parties.

Some crimping of the anchor legs may be required to secure the anchor to the window leg during installation.

2. Move window into position in the building opening.
3. Shim tight between the masonry opening and the back of the “F” anchor with high strength plastic or non-corrosive materials Not by EFCO.
4. Install fasteners in “F” anchor per structural requirements.

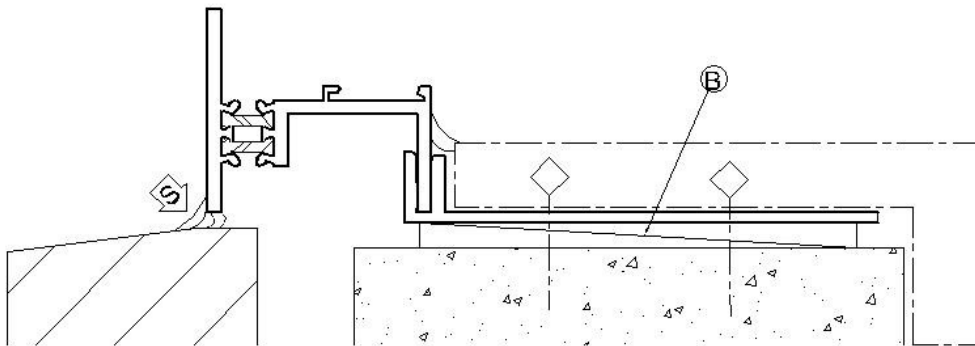

SYMBOLS LEGEND	
◇	INDICATES ANCHOR FASTENER BY THE ERECTOR
S	INDICATES FIELD APPLIED SEALANT (NOT BY EFCO)
B	INDICATES BLOCKING BY THE ERECTOR
FD	INDICATES DRILLING BY THE ERECTOR

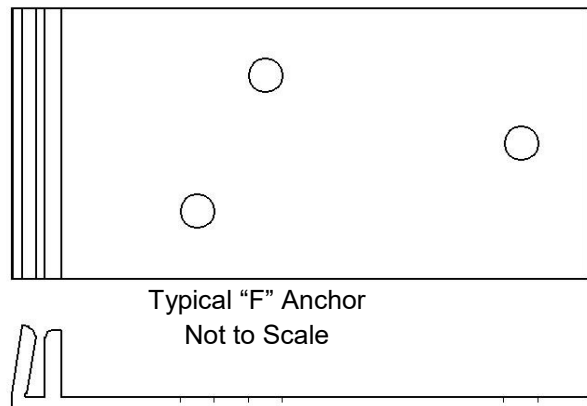

Completely read the General Installation Instructions and all other sections which pertain to your project before starting work. These recommendations are for general erection procedures only. For actual job conditions, see the details on the shop drawings. For perimeter anchor types and spacing, refer to the approved shop drawings or consult the project design professional.

Installation of Architectural Sills

1. Establish location of the architectural sill from approved project shop drawings.
2. Locate the architectural sill anchor clip positions as noted on the shop drawing and or anchorage calculations by the responsible parties.
3. Drill the anchor hole using the anchor clip as a template.
4. Shim the clips and sill as necessary to set level across the span of the opening
5. Based on the approved project shop drawings, apply a bed of grout or a high impact resistant shim for the architectural sill to rest on.
6. Hook the exterior leg of the architectural sill over the exterior leg of the anchor clip, and press the sill into a bed of grout/sealant.

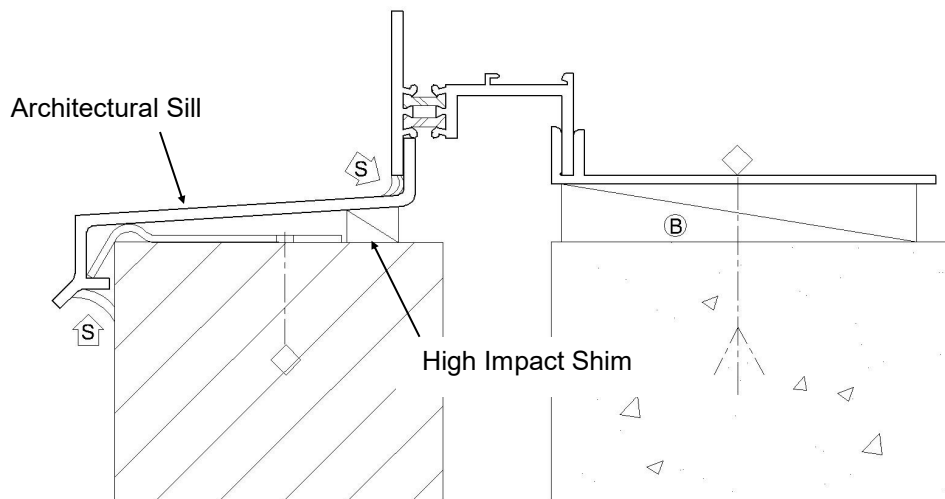

SYMBOLS LEGEND	
◇	INDICATES ANCHOR FASTENER BY THE ERECTOR
⊞	INDICATES FIELD APPLIED SEALANT (NOT BY EFCO)
ⓑ	INDICATES BLOCKING BY THE ERECTOR
Ⓣ	INDICATES DRILLING BY THE ERECTOR

Completely read the General Installation Instructions and all other sections which pertain to your project before starting work. These recommendations are for general erection procedures only. For actual job conditions, see the details on the shop drawings. For perimeter anchor types and spacing, refer to the approved shop drawings or consult the project design professional.

Installation of Gravity Anchors

Typically gravity anchors are used for two reasons.

1. To hold one window up off another window to allow for thermal expansion. (Not usually used for vertical bays less than 10 feet tall.)
2. To hold the weight of the upper window off the lower window to keep the head from bowing or twisting.

HA90 Gravity Anchor

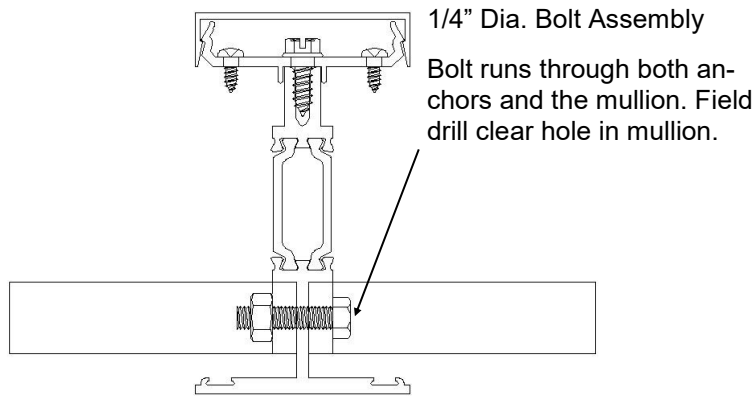
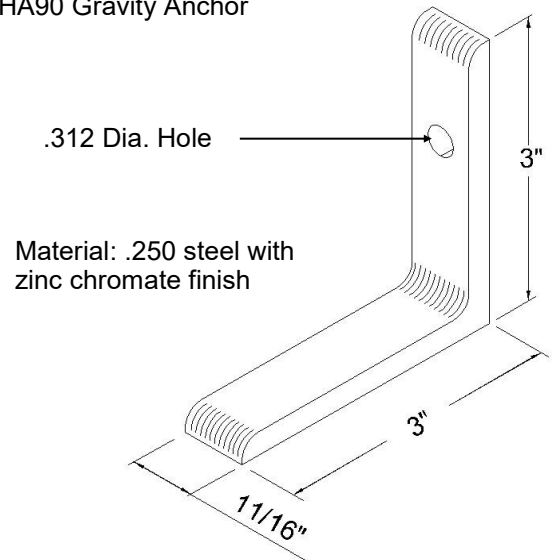

Typical Gravity Anchor at a Mullion

Hole for anchorage to opening or mullions.

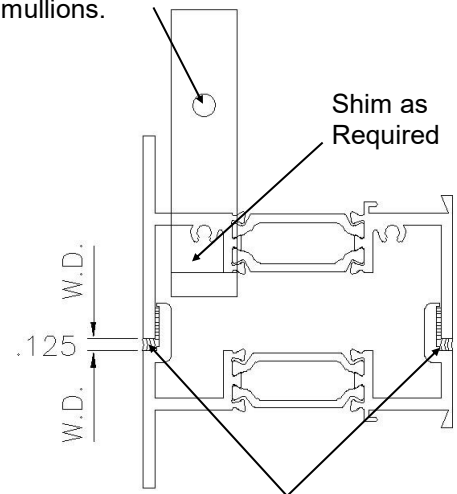

Typical Horizontal Stack Joint

Note:
All stacks & subsills must be set in a bed of sealant to ensure a watertight seal (Interior and Exterior).

SYMBOLS LEGEND	
◇	INDICATES ANCHOR FASTENER BY THE ERECTOR
S	INDICATES FIELD APPLIED SEALANT (NOT BY EFCO)
B	INDICATES BLOCKING BY THE ERECTOR
FD	INDICATES DRILLING BY THE ERECTOR

Completely read the General Installation Instructions and all other sections which pertain to your project before starting work. These recommendations are for general erection procedures only. For actual job conditions, see the details on the shop drawings. For perimeter anchor types and spacing, refer to the approved shop drawings or consult the project design professional.

General Installation of Stacking Window Systems

If side stacking is utilized, it will be necessary to either stack the units together prior to placing them in the opening, or placing them in the opening and sliding all units to one side, allowing for the last unit to be installed.

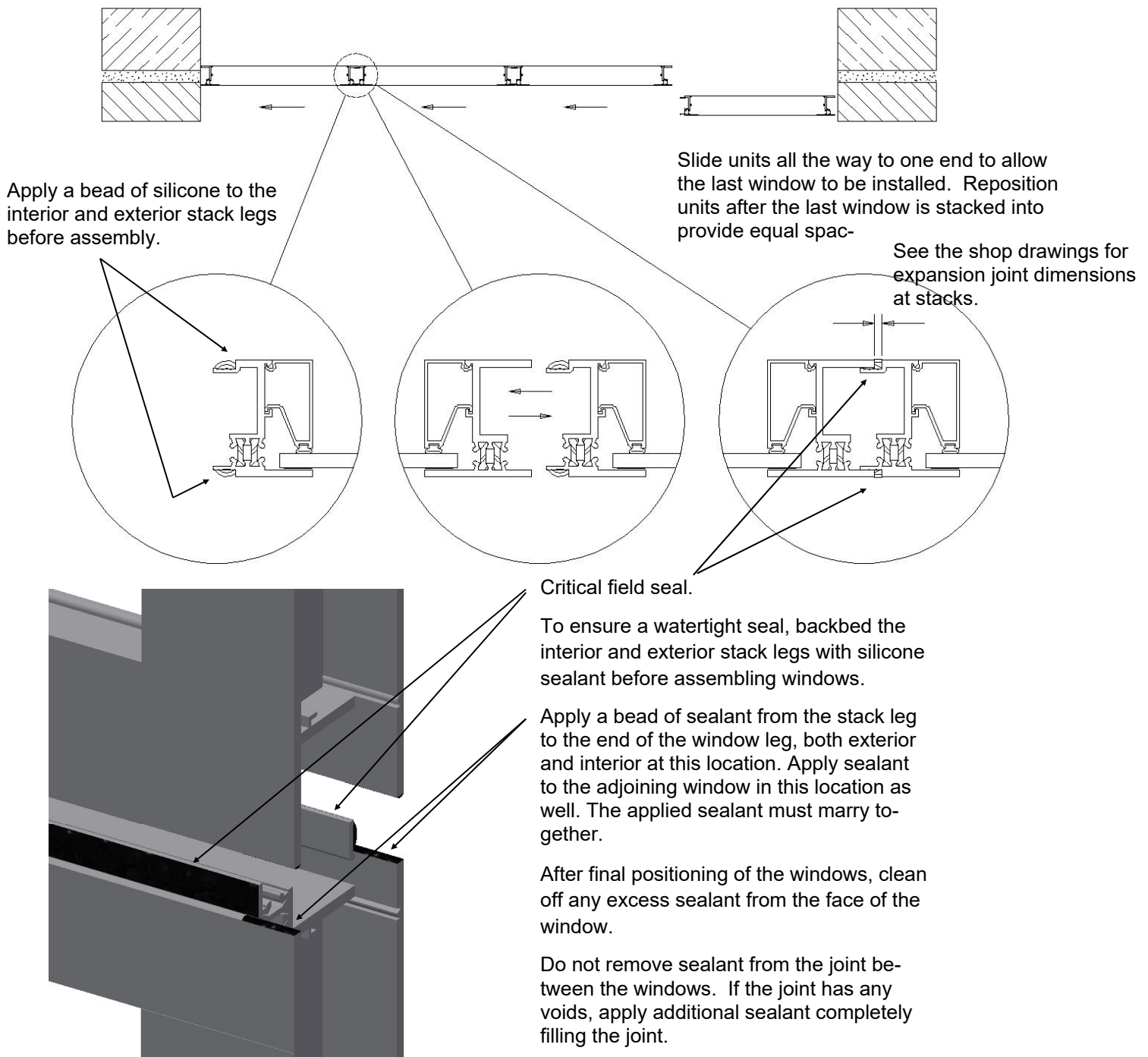

Completely read the General Installation Instructions and all other sections which pertain to your project before starting work. These recommendations are for general erection procedures only. For actual job conditions, see the details on the shop drawings. For perimeter anchor types and spacing, refer to the approved shop drawings or consult the project design professional.

Installation of Mullions When Not Using Subframe or Panning

1. Refer to the shop drawings for the correct center line location of the mullion.
2. For elevations not using Subframe or Panning, mullions are supplied at the rough opening height plus 2" (square cut) to allow for field trimming as required
3. Set the mullion into the opening. Plumb the mullions to the opening. Fasten the mullion to the opening by using two EFCO supplied mullion anchor clips (FDS6). Locate one clip at the masonry head and one at the masonry sill. Attach the clips to the opening with erector furnished fasteners, then attach the mullion to the mull anchors with EFCO furnished fasteners.
4. Back bed the window to mullion contact area with silicone sealant before installing the window, or cap seal after the window is installed.
5. Attach the mullion pressure clips to the mullion as close to the top end as possible, and then 16" on center with EFCO supplied fasteners. Spacing may need to be reduced depending on design pressure and anchorage conditions. Refer to the approved shop drawings or consult the project design professional.
Attach the 4" mullion pressure clips to the mullion at the bottom end. The 4" clip should contact the sill flashing or other adjoining horizontal surface. This bottom clip forms a water dam under some opening conditions. Seal the clip to the condition at the sill and up the sides. The screw heads on this bottom clip should also be sealed over.
6. Attach the mullion clips to each window jamb with EFCO supplied fasteners. Make sure the window jamb remains square and plumb. (Field drilling of window jambs by the erector.)
7. Field cut the vertical mullion cover to fit between the opening conditions and snap over the mullion clips.

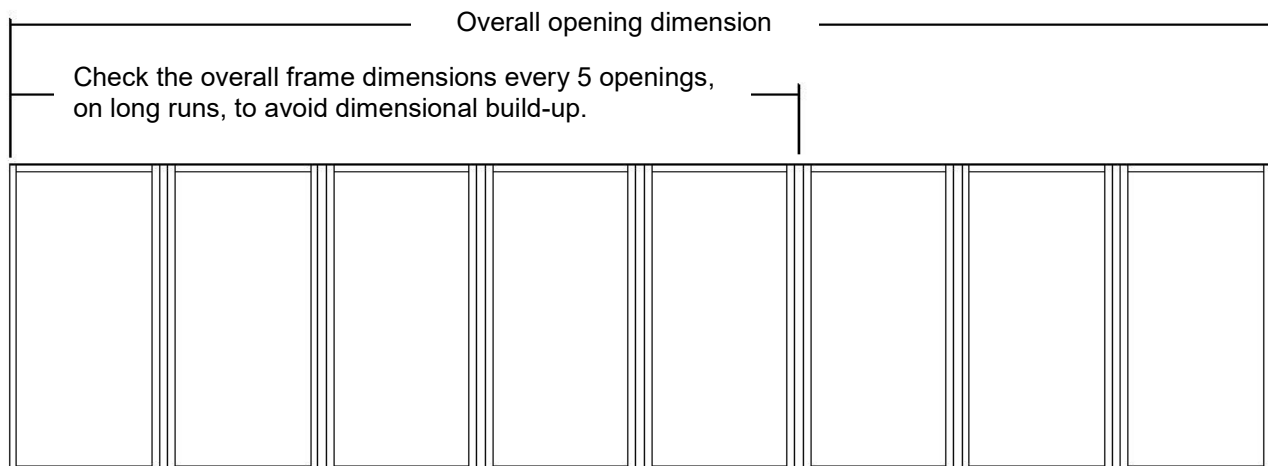

Completely read the General Installation Instructions and all other sections which pertain to your project before starting work. These recommendations are for general erection procedures only. For actual job conditions, see the details on the shop drawings. For perimeter anchor types and spacing, refer to the approved shop drawings or consult the project design professional.

Procedure A

Back seal prior to window installation.

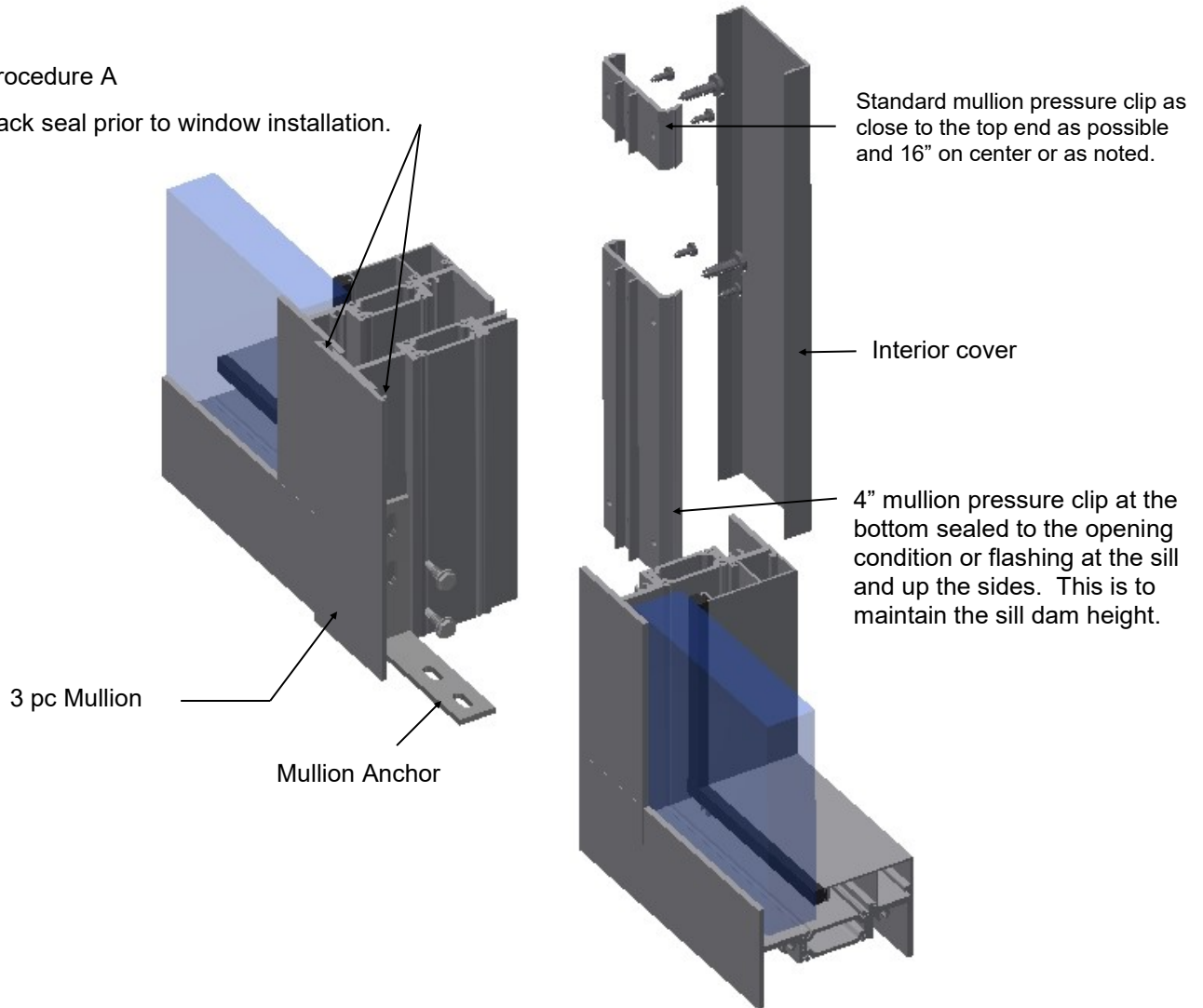

Spacing varies, see shop drawings.

Procedure B

Critical seal, cap bead with silicone sealant.

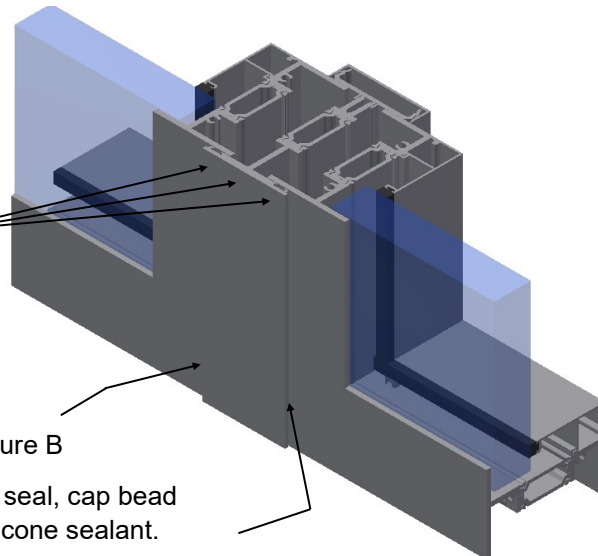

Completely read the General Installation Instructions and all other sections which pertain to your project before starting work. These recommendations are for general erection procedures only. For actual job conditions, see the details on the shop drawings. For perimeter anchor types and spacing, refer to the approved shop drawings or consult the project design professional.

Reversed Mullion Installation

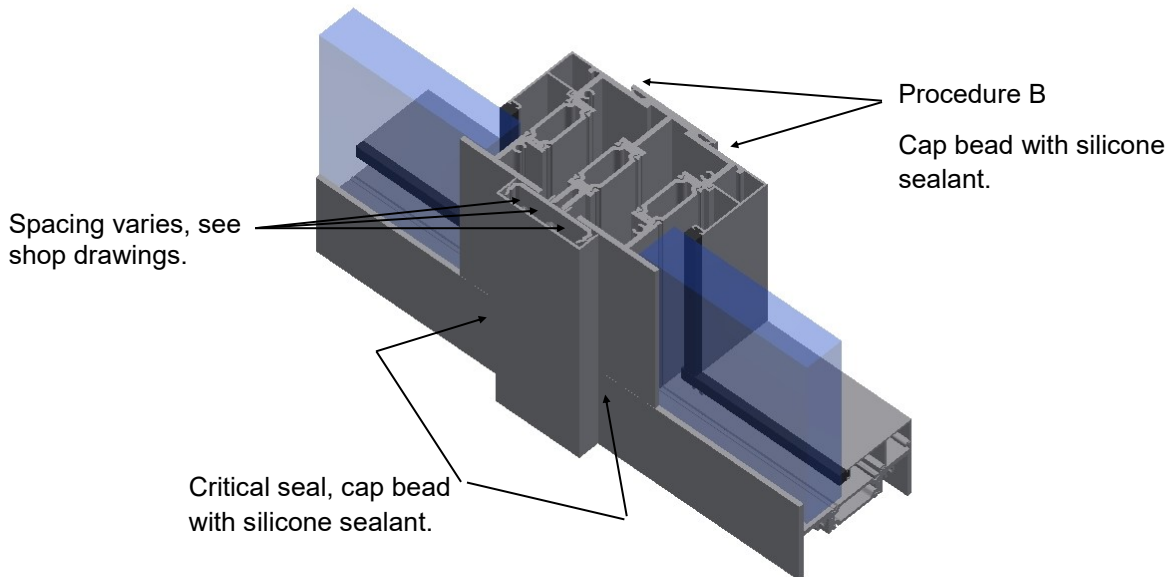
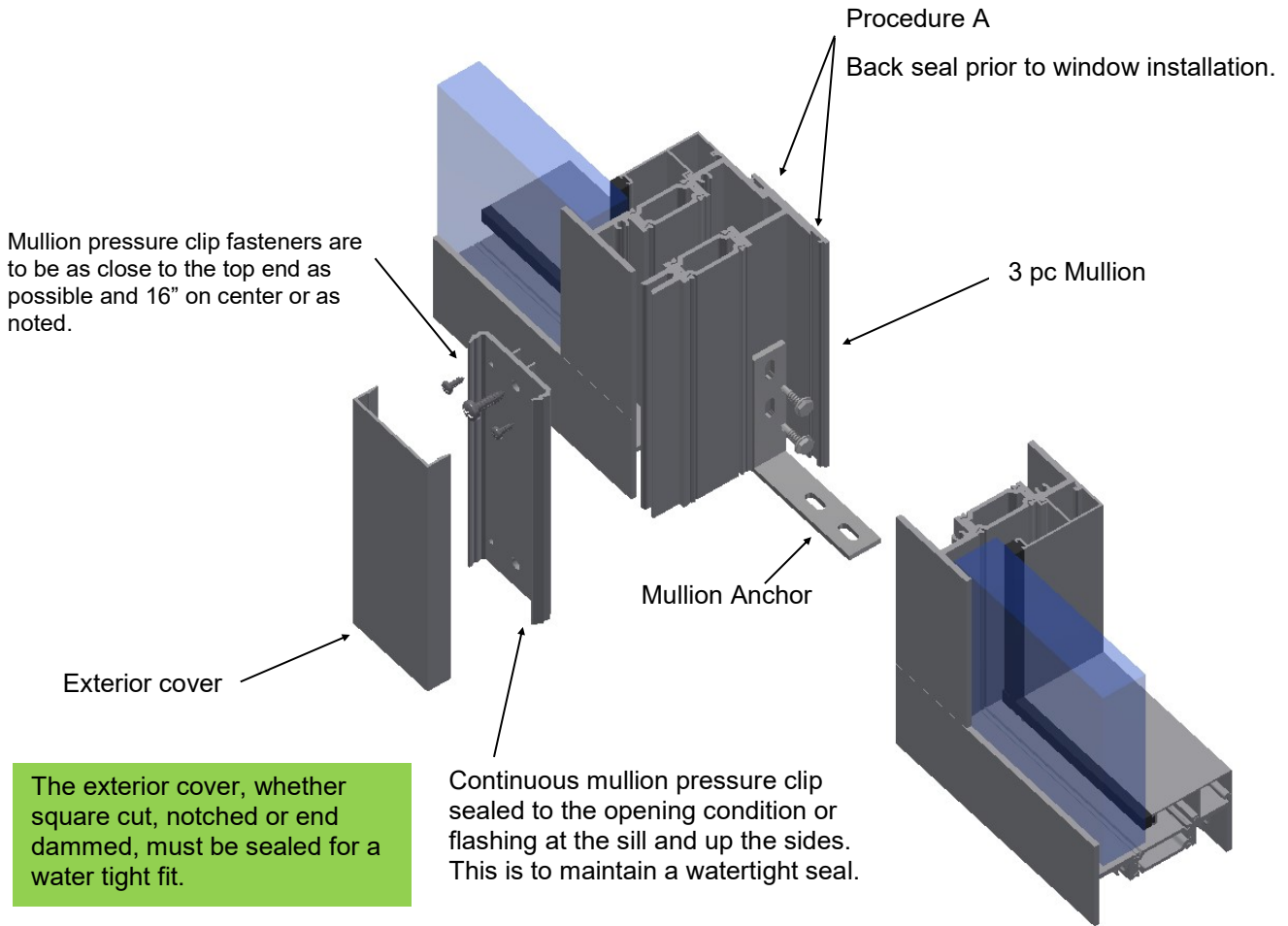

Completely read the General Installation Instructions and all other sections which pertain to your project before starting work. These recommendations are for general erection procedures only. For actual job conditions, see the details on the shop drawings. For perimeter anchor types and spacing, refer to the approved shop drawings or consult the project design professional.

General Installation Instructions for Optional Frame Extenders

Frame extender material is shipped loose for field installation. The perimeter flange, of the frame extender, may be field trimmed to fit the masonry opening if necessary.

1. Frame extenders will assemble around the window or accessories perimeter.
2. Determine the correct window placement in the opening. Refer to the shop drawing details, for correct placement in the opening, in order to allow for correct coverage.
3. The frame extenders may be coped or mitered, as specified by the project, before assembly to the window.

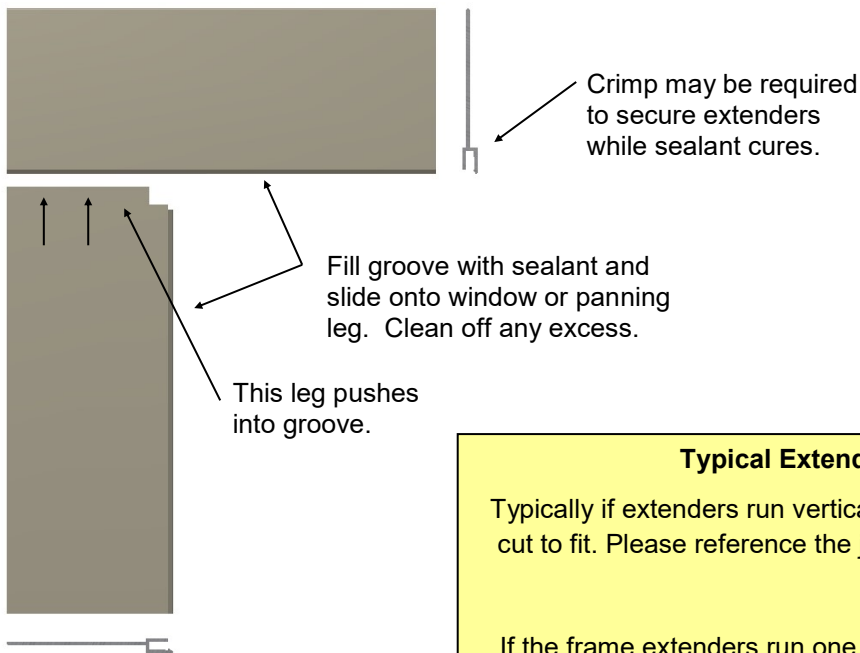

Typical Extender Corner

Typically if extenders run vertical and horizontal EFCO will cut to fit. Please reference the job specifications to verify.

If the frame extenders run one direction only, they will be sent long for field cut.

Completely read the General Installation Instructions and all other sections which pertain to your project before starting work. These recommendations are for general erection procedures only. For actual job conditions, see the details on the shop drawings. For perimeter anchor types and spacing, refer to the approved shop drawings or consult the project design professional.

4. Fill the frame extender cavity using a sealant with 50% movement. Push the frame extender into place. The frame extender must be fully wet sealed to the window. Clean off excess sealant from any exposed areas.

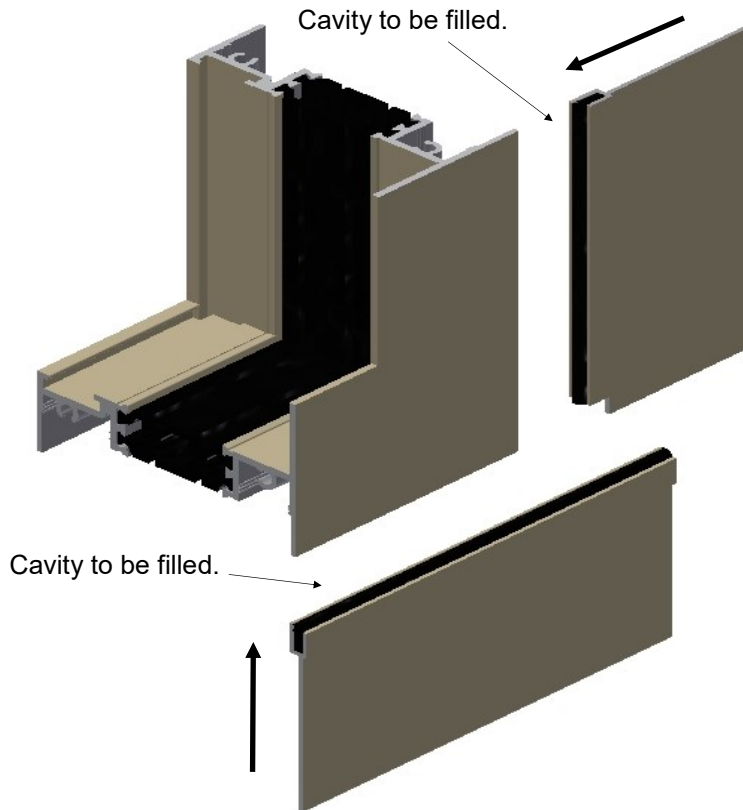

5. Use silicone sealant to cover all of the frame joints, on the non-exposed side of the frame extender if they are to be exposed. Tool sealant as necessary.

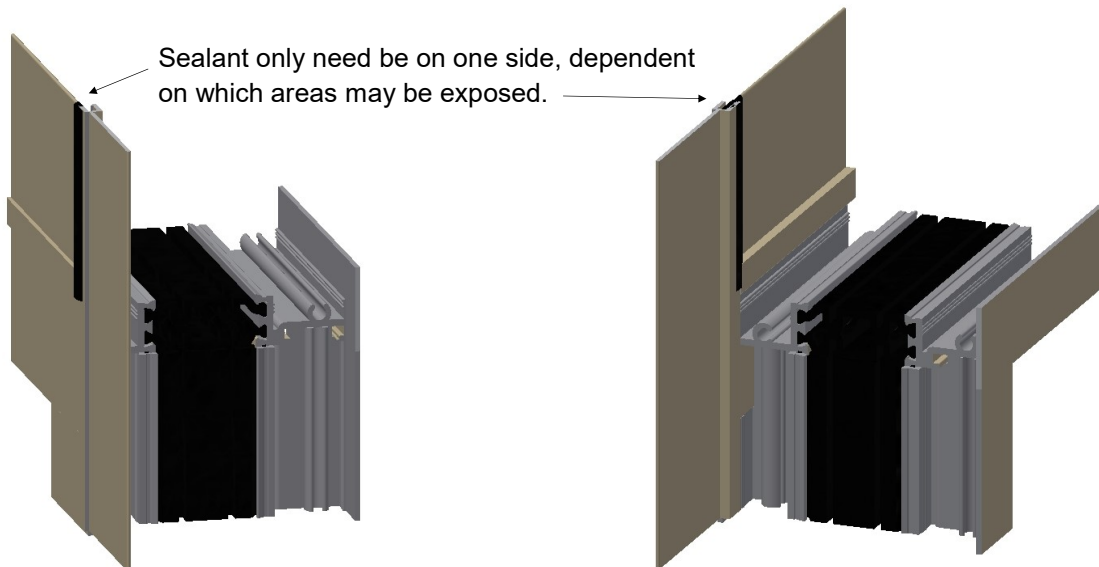

Completely read the General Installation Instructions and all other sections which pertain to your project before starting work. These recommendations are for general erection procedures only. For actual job conditions, see the details on the shop drawings. For perimeter anchor types and spacing, refer to the approved shop drawings or consult the project design professional.

6. Clean and prepare the opening for sealant. Before application of the sealant, verify that the sealant will be covered by the frame extender, when the window is installed into the opening.

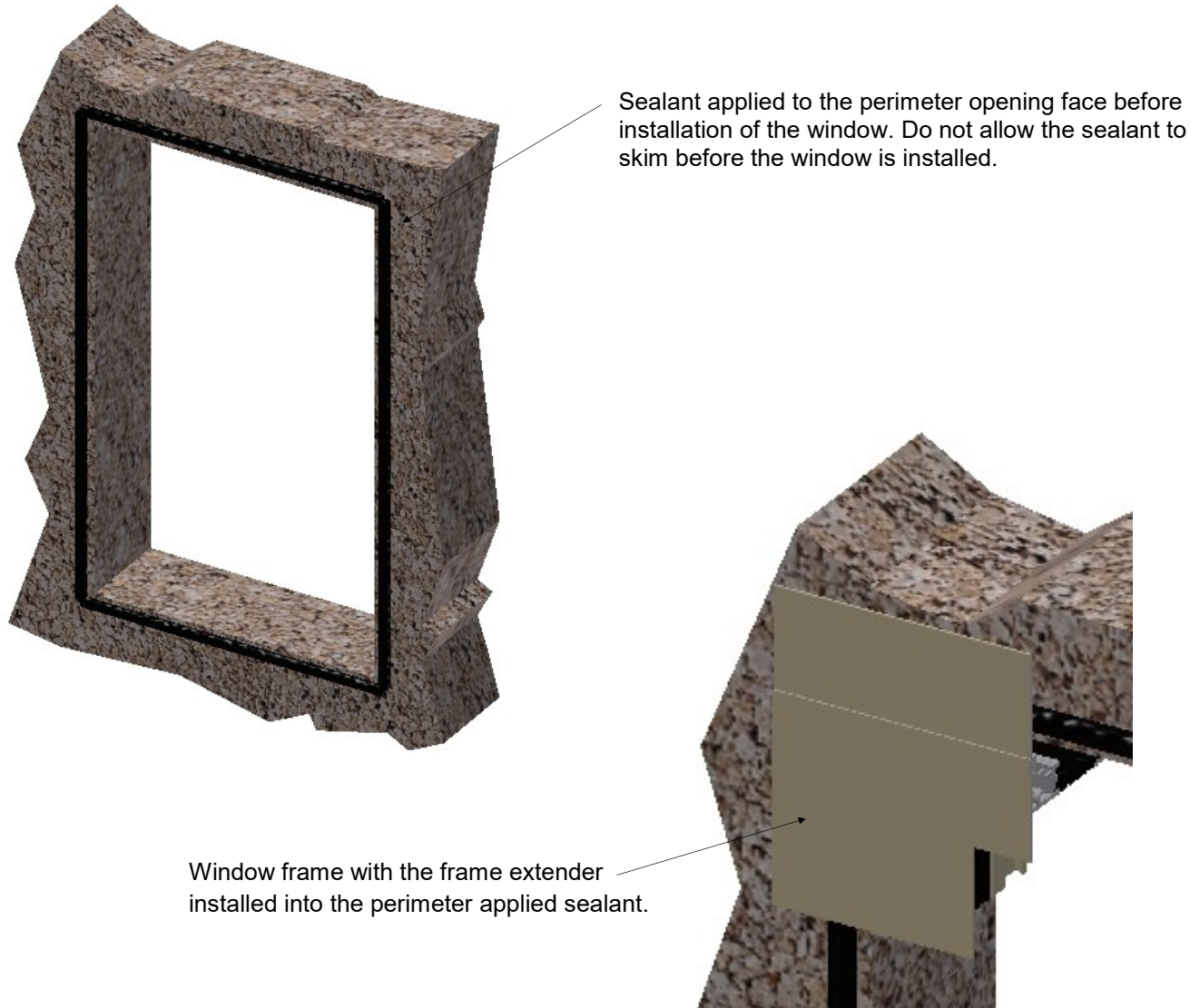

7. Attach the entire window, square, plumb, and level into the opening with attachment screws by others. All blocking, sealants, and perimeter fasteners are Not by EFCO.

For perimeter anchor type and spacing, refer to the approved shop drawings or consult the project design professional.

8. Caulk the perimeter of the framing to the surrounding masonry opening. Tool sealant as necessary.

9. Install the interior finish work, as required, per the project specifications.

Completely read the General Installation Instructions and all other sections which pertain to your project before starting work. These recommendations are for general erection procedures only. For actual job conditions, see the details on the shop drawings. For perimeter anchor types and spacing, refer to the approved shop drawings or consult the project design professional.

General Installation Instructions for Hung Windows

Note: Customer to assure limit stops are in place on all hung windows – contact AFS if missing.

1. Install the frame plumb, level, and true. It is critical for the window operation that the jambs are parallel without bow or twist. The sash may be removed while installing the frame at the installer's discretion. All sash removed must go back into the same frame from which it was removed. All sash that are removed should be marked accordingly to avoid confusion.

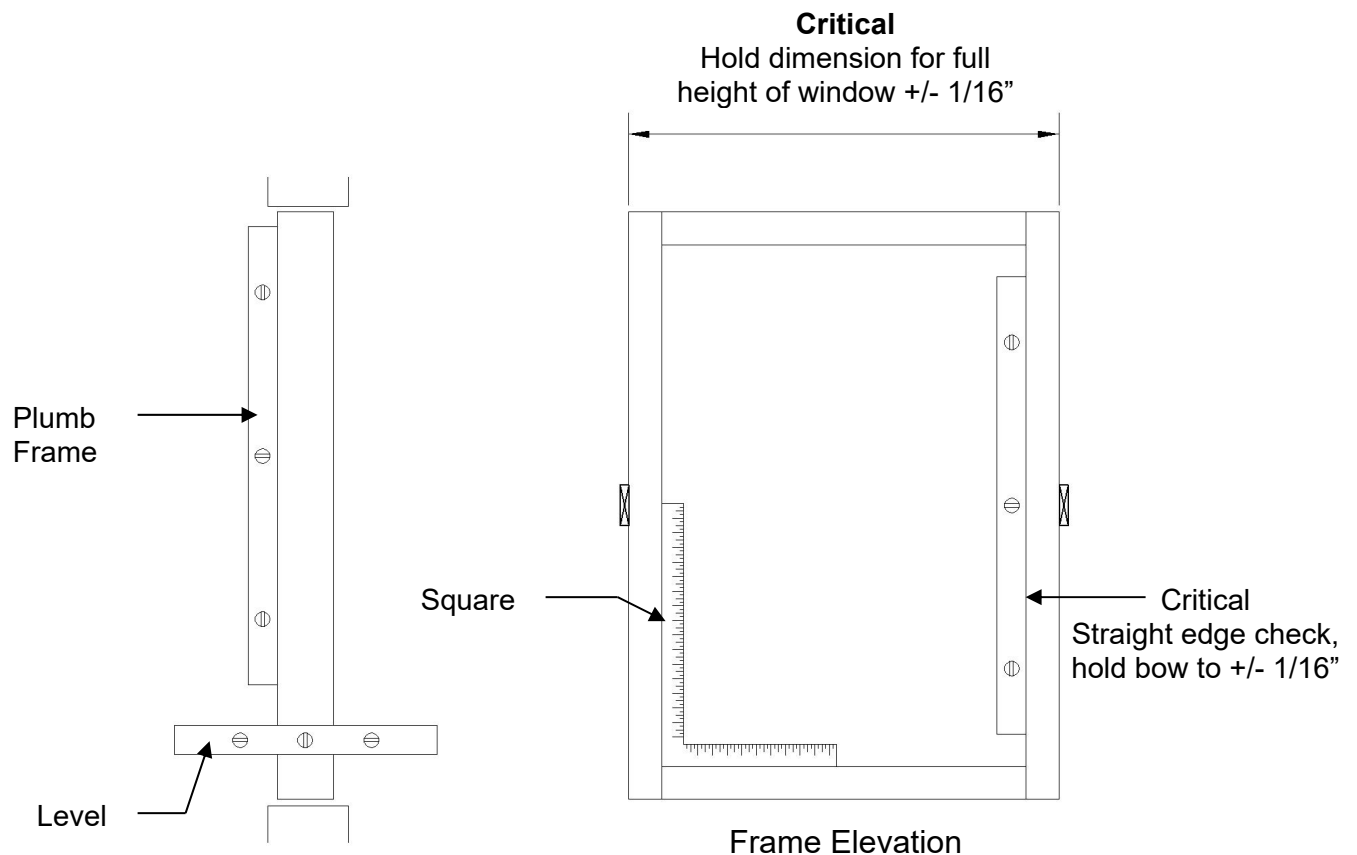

2. All hung windows are to be blocked and anchored at jamb midpoints as detailed on the project shop drawings in order to prevent the jambs from bowing or twisting. The window dimension at the midpoint shall be within 1/16" of the window dimension at the head and/or sill.
3. Some hung windows are shipped with temporary spring locks attached at the sash handle rail to prevent shipping damage. When not required for the project, these locks must be removed before installing the window into the opening.

Completely read the General Installation Instructions and all other sections which pertain to your project before starting work. These recommendations are for general erection procedures only. For actual job conditions, see the details on the shop drawings. For perimeter anchor types and spacing, refer to the approved shop drawings or consult the project design professional.

4. Double hung windows are shipped from the factory with a temporary shipping device. This device must remain attached to the window until just prior to installation into the opening. Early removal can cause rolling, spreading, and twisting of the jamb. This may cause disengagement of the sash balance, disengagement of the sash from the frame, or severe personal injury.

5. Due to the attachment and location of all balances, refer to the project shop drawings for any through jamb anchorage method. (All fasteners at jamb locations shall be flat heads.)

Completely read the General Installation Instructions and all other sections which pertain to your project before starting work. These recommendations are for general erection procedures only. For actual job conditions, see the details on the shop drawings. For perimeter anchor types and spacing, refer to the approved shop drawings or consult the project design professional.

Tilt Window Sash Removal and Cleaning Instructions

1. Unlock the bottom sash and raise it a minimum of 4". Note: On double hung units, remove the bottom sash first, then lower the top sash a minimum of 4".
2. Remove the sash by disengaging the tilt lock from the jamb and tilting the top of the sash down to a horizontal position. Lift or rotate one side of the sash to disengage the tilt pin from the pivot shoe assembly. Lift the other side of the sash up and remove it from the window frame.

Note: Sash that are removed must go back into the same frame from which it was removed.

3. Proceed with specified glass care and cleaning instructions for the appropriate glass type in the unit.
4. If the unit is double hung, the top sash can be removed in the same fashion as the bottom sash by repeating steps 1 and 2.
5. To reinstall sash, repeat the procedure in reverse.

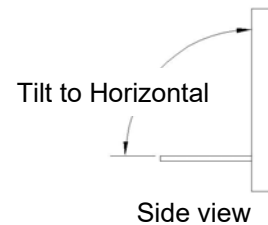
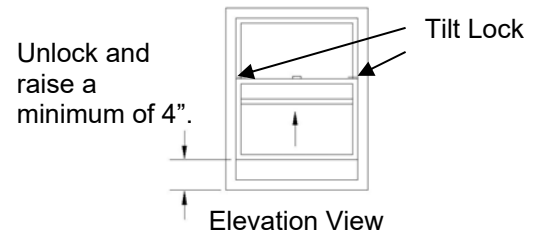

Rotate and remove lower sash.

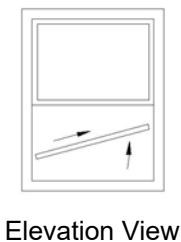

Warning

When installing sash, be sure the tilt pins are properly engaged into the pivot shoe assembly, and that the tilt locks are fully engaged into the jamb with the set screw properly locked down. Personal injury or damage to the window may result if instructions are not followed.

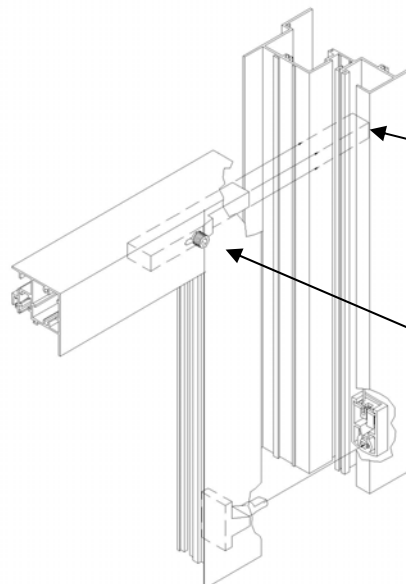

Warning
The Tilt lock must fully engage the jamb.

Warning
The set screw must be tightened down to almost flush with the surface of the sash.

Completely read the General Installation Instructions and all other sections which pertain to your project before starting work. These recommendations are for general erection procedures only. For actual job conditions, see the details on the shop drawings. For perimeter anchor types and spacing, refer to the approved shop drawings or consult the project design professional.

Tilt Window Balance Removal and Installation

Removal of lower sash and balance

1. Follow sash removal procedures as outlined in steps 1 and 2 of the previous page.
2. Insert a large flat screwdriver in the pivot shoe assembly cam. With caution, while maintaining downward pressure, slowly rotate the cam until the cam slot is horizontal. Using the screwdriver as a lever, allow the pivot shoe assembly to rise to within 2 inches of the balance housing, relieving most of the tension on the balance. Rotate the cam back to a vertical position to relock the pivot shoe assembly.
3. Using needle nose pliers, release the balance cord clip(s) from the pivot shoe assembly allowing the cord to retract into the balance slowly. Use caution not to damage the cord.
4. Again rotate the pivot shoe cam to the horizontal allowing the assembly to drop to the bottom of the jamb.
5. If only one balance is in the track, remove the screw at the top of the balance and remove the balance from the track.

With two balances in the track, slide one balance to the bottom of the jamb while holding the second balance in position at the top. Twist the bottom balance from the bottom end and gently work it out where it overlaps the other balance at the midpoint of the jamb. Remove the top balance if required.

If you have an unequal sash with dual balances, some proportions require that you must remove the window unit and disassemble the sill member from the jamb members. This allows for removal of the balances by sliding them out the bottom. Failure to remove the balances in this manner will result in damage to the window members and both balances.

Removal of upper sash and balances

6. Lower upper sash approximately 4 inches and repeat the above steps

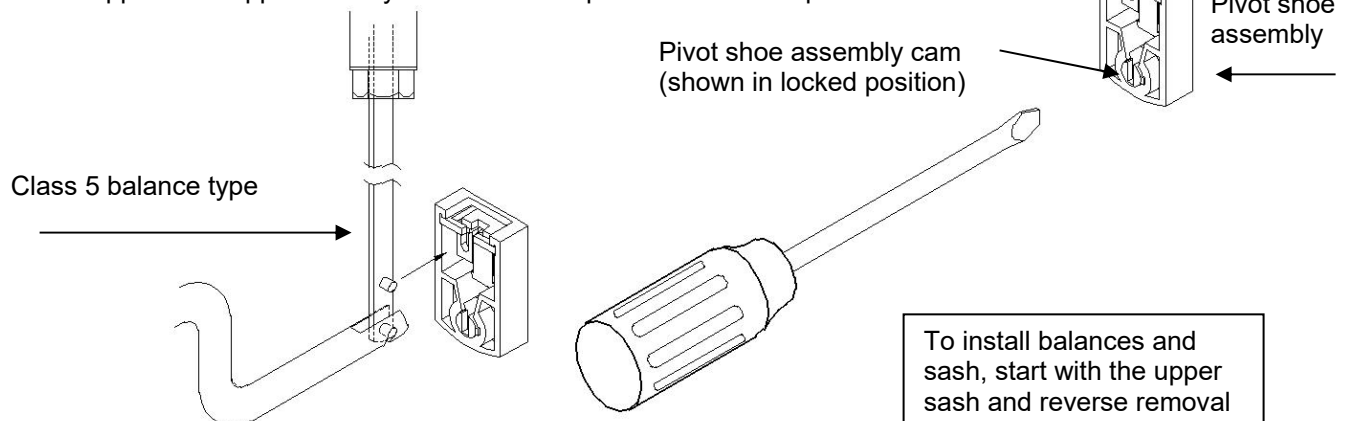

Completely read the General Installation Instructions and all other sections which pertain to your project before starting work. These recommendations are for general erection procedures only. For actual job conditions, see the details on the shop drawings. For perimeter anchor types and spacing, refer to the approved shop drawings or consult the project design professional.

Side Load Sash and Balance Removal for Block and Tackle Balances

Removal of lower sash and balance

1. Remove the sash stop at the head of the window.
2. Pull the bottom of the spring clip outward.
3. Raise the sash until the balance slides under the spring clip.
4. Lift the sash 2 or 3 inches above the balance. Move the sash right or left as far as possible. Then swing the opposite side of the sash toward the interior.
5. Remove the balance by pressing downward on the balance, moving it out from under the spring clip. Relax the tension and remove the terminal clip from the square hole in the window jamb.

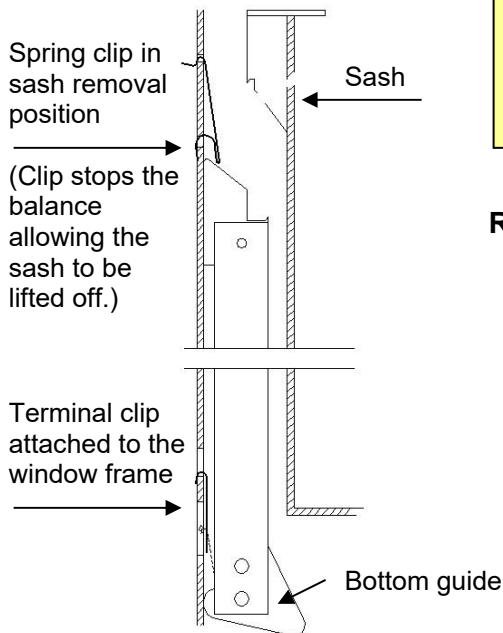
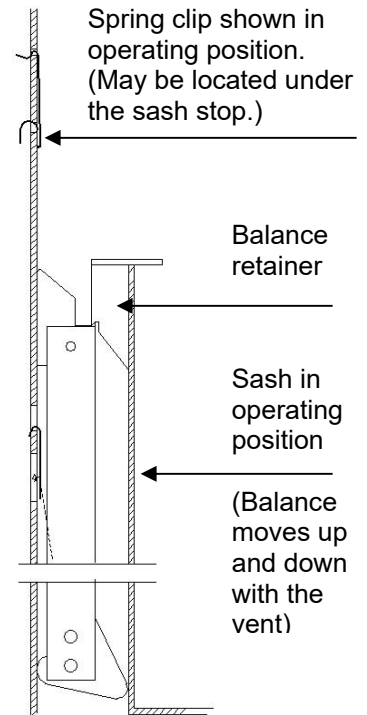

Caution
Balances can be under extreme tension.

Removal of upper sash and balance

1. Lower the upper sash to expose the spring clip and pull the bottom of the clip outward.
2. S-670 only – Move the dust stops toward the center of the window by depressing the button on the bottom of the meeting rail, then slide the dust stop. (Do not remove screw in bottom of dust stop.)
S-675 or 676 only – Remove both dust stops by removing two screws from each.
3. Repeat steps 3 to 5 indicated in removal of the lower sash and balance procedure.

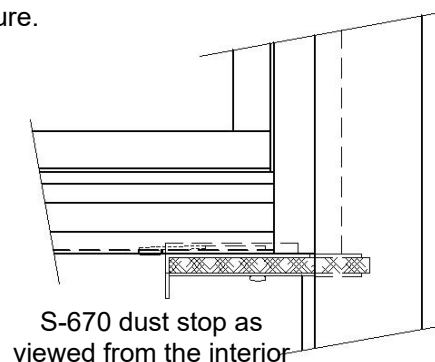
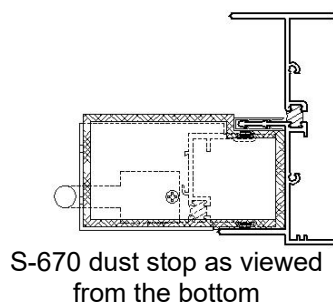

Completely read the General Installation Instructions and all other sections which pertain to your project before starting work. These recommendations are for general erection procedures only. For actual job conditions, see the details on the shop drawings. For perimeter anchor types and spacing, refer to the approved shop drawings or consult the project design professional.

Side Load Sash and Balance Removal for Class 5 Balances With Third Generation Carriers

Sash Removal

Remove both lower sash end caps.

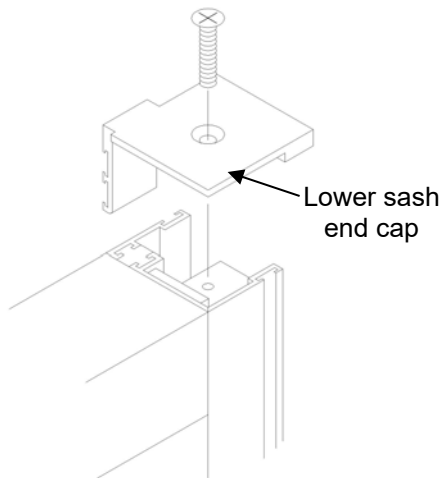

1. Raise the lower sash so you can comfortably reach the underside of the sash handle rail. If the sash travel has been limited, the limit stops may have to be removed.
2. The carrier body is located in the jamb pocket at the bottom end of the sash side rails. A hook in the bottom of the carrier body is held in place by a flex spring. Insert a flat blade screwdriver between the upturned edge of latch and bottom of carrier. Pry screwdriver towards center using corner of sash as a pivot point until latch snaps free of carrier guide.
3. Latch should now be hanging against the back of the jamb channel. Lower the sash slowly until the carrier body hook is below the jamb hold down blocks. Raise the sash again until the hooks engage the jamb hold down blocks. The carrier body will be held in place when the sash is removed.

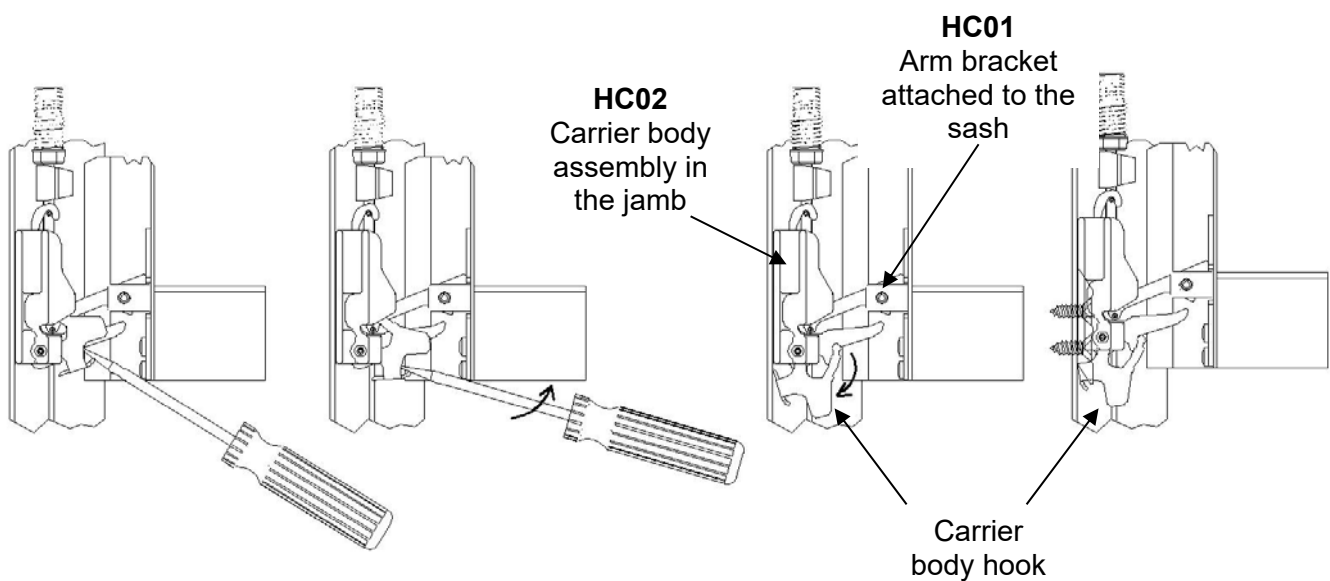

Completely read the General Installation Instructions and all other sections which pertain to your project before starting work. These recommendations are for general erection procedures only. For actual job conditions, see the details on the shop drawings. For perimeter anchor types and spacing, refer to the approved shop drawings or consult the project design professional.

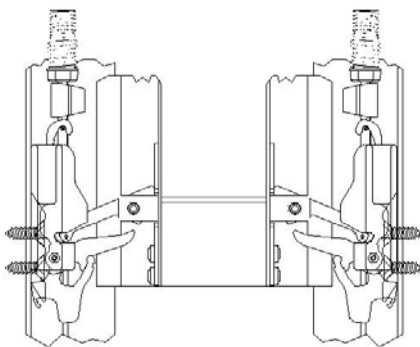

4. Sash at rest in hold down position.

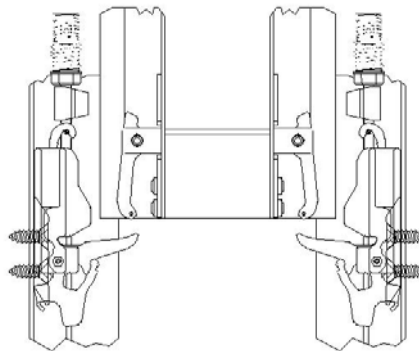

5. Lift the sash off the carrier body about two inches.

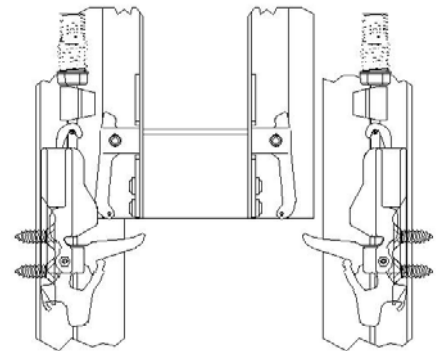

6. Move the sash into one of the jamb pockets as far as possible. Swing the opposite side of the sash inward and remove sash.

Balance Removal

7. After the sash has been removed, pull off the HB00 tamper clips on the end of the balance, just above the carrier body.

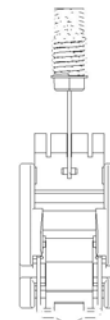
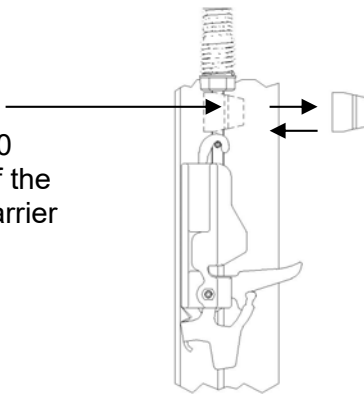

Single balance mounting uses center slot only.

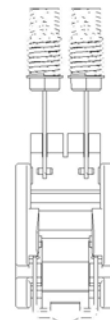

Tandem balance mounting uses outer slots of the carrier.

Mounting a single balance in outside slots of carrier will result in higher operating forces.

Completely read the General Installation Instructions and all other sections which pertain to your project before starting work. These recommendations are for general erection procedures only. For actual job conditions, see the details on the shop drawings. For perimeter anchor types and spacing, refer to the approved shop drawings or consult the project design professional.

Caution
Balances can be under extreme tension.

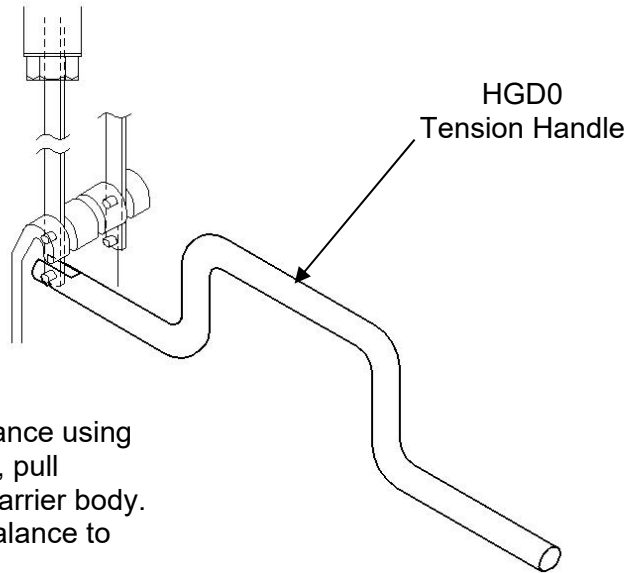

Balance or Carrier Removal

1. Carefully pull down on the bottom of the balance using a balance tensioning tool. As you pull down, pull forward to disengage the balance from the carrier body. Slowly, with a controlled motion, allow the balance to retract.
 2. Remove the sash stop to expose the screw in the top end of the balance. Back out the balance attachment screw and remove the balance from the jamb cavity.
 3. With the balances out of the jamb cavity, the balance carrier can be slid to the top of the jamb cavity and removed.
- For the upper sash of a double hung, the carrier is removed from the bottom end of the outer jamb cavity.
4. Reinstallation would be a similar procedure in reverse order.

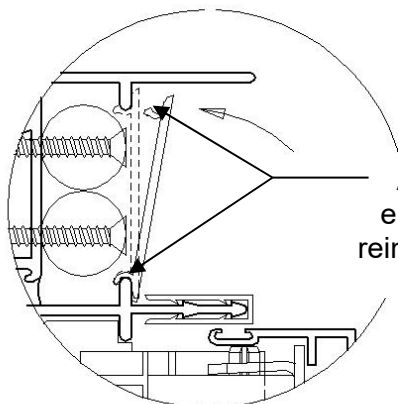
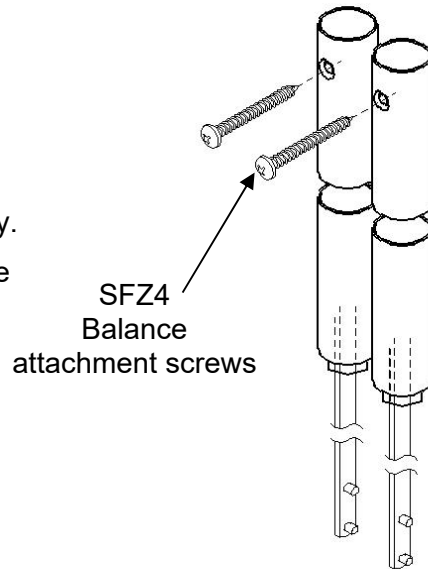

Apply silicone to 3" of the engagement surfaces when reinstalling frame filler material.

Completely read the General Installation Instructions and all other sections which pertain to your project before starting work. These recommendations are for general erection procedures only. For actual job conditions, see the details on the shop drawings. For perimeter anchor types and spacing, refer to the approved shop drawings or consult the project design professional.

Appendix – HX45 Sash Shipped Separate From Frame Due To Window Height

HX45 LC67 Meeting Rail Separator

1. Upper sash must be installed prior to LC67 attachment.
2. Verify that all weather stripping is in place within the meeting rail separator before installation.
3. If weather stripping is missing install as shown below.
4. Install LC67 meeting rail separator onto the upper sash.
5. Attach to upper sash using #8-15 x $\frac{3}{4}$ " fasteners (SPZ6) at pre-fabricated hole locations.
6. After LC67 meeting rail separator is attached to the upper sash the lower sash can be installed.

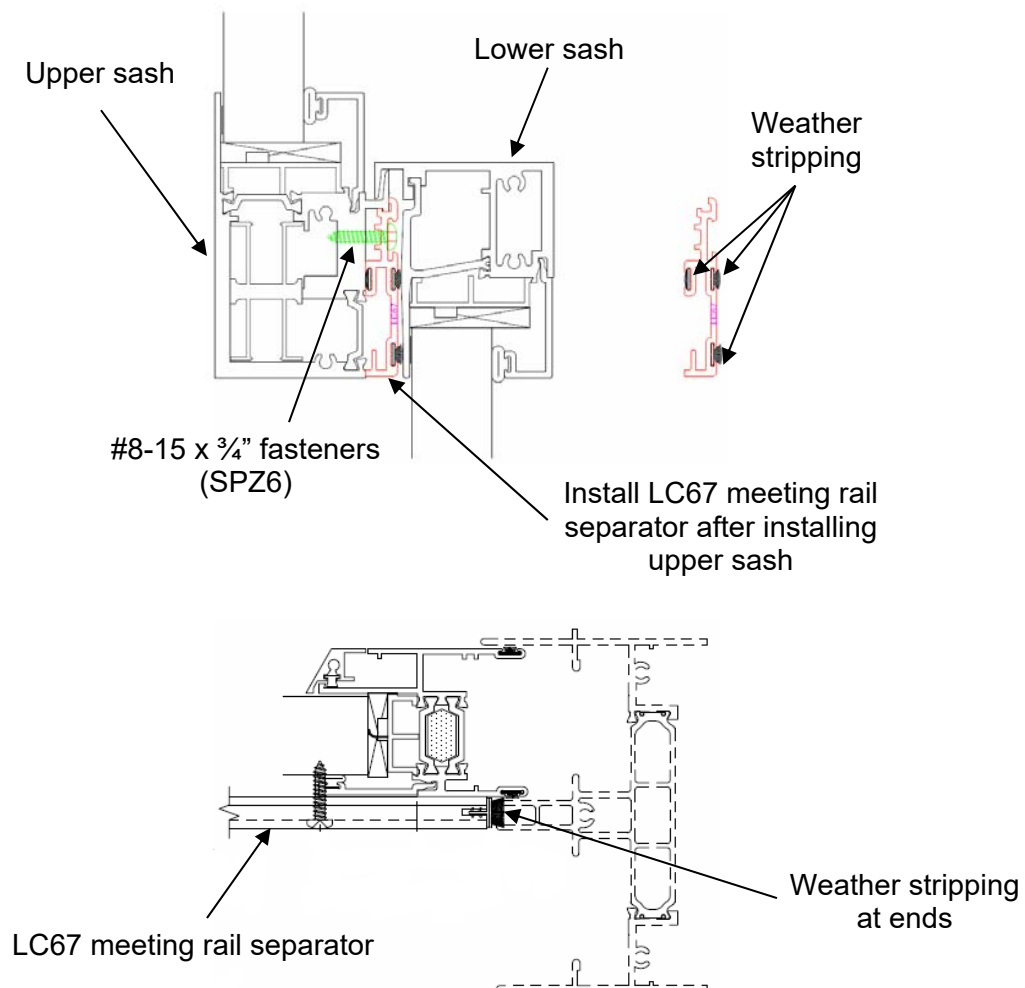

Completely read the General Installation Instructions and all other sections which pertain to your project before starting work. These recommendations are for general erection procedures only. For actual job conditions, see the details on the shop drawings. For perimeter anchor types and spacing, refer to the approved shop drawings or consult the project design professional.

Horizontal Sliding Window Sash Removal

1. Remove sash stop (HB53) by removing screw (STK0). The sash stop is located in the head track opposite the sash.

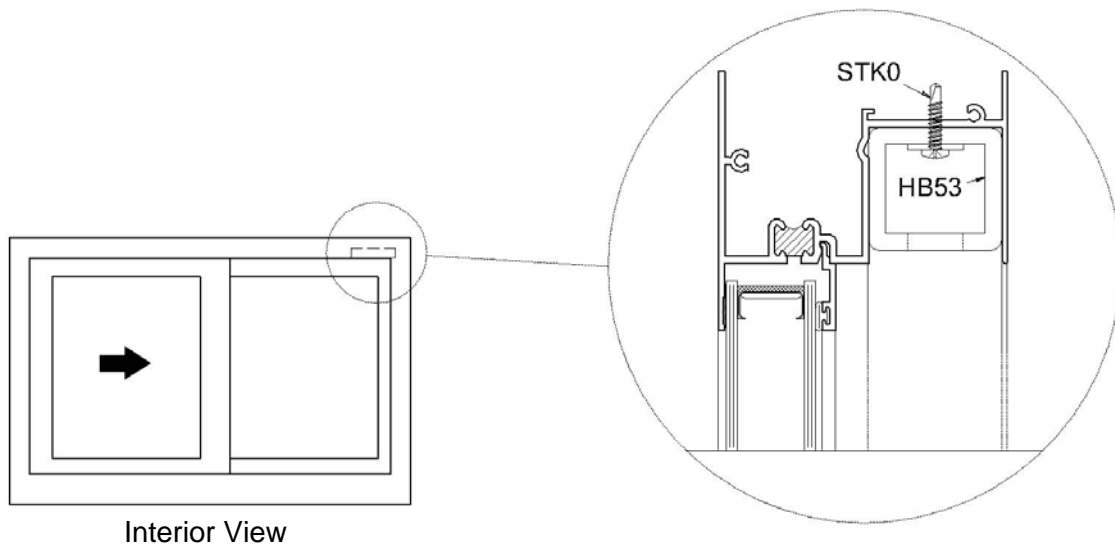

2. Remove anti-rack / anti-takeout filler (LB24) by pulling down on the side nearest the jamb. This end is next to sash stop you just removed.

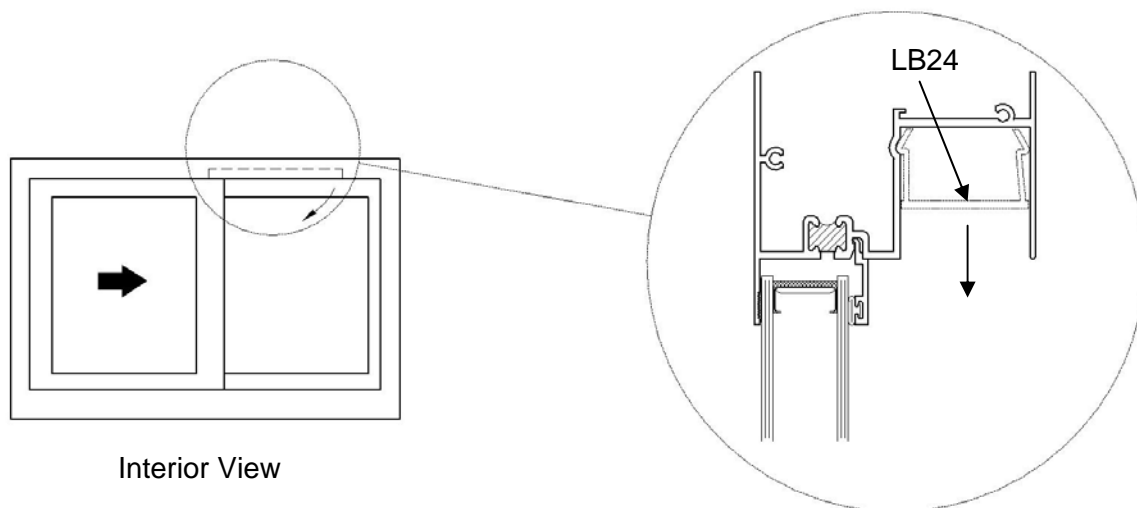

Completely read the General Installation Instructions and all other sections which pertain to your project before starting work. These recommendations are for general erection procedures only. For actual job conditions, see the details on the shop drawings. For perimeter anchor types and spacing, refer to the approved shop drawings or consult the project design professional.

- Remove anti-rack / anti-takeout filler (LB24) over the sash by opening the sash all the way. Slide the LB24 away from the jamb just far enough to get your finger between it and the jamb. Pull down on the filler with finger and remove.

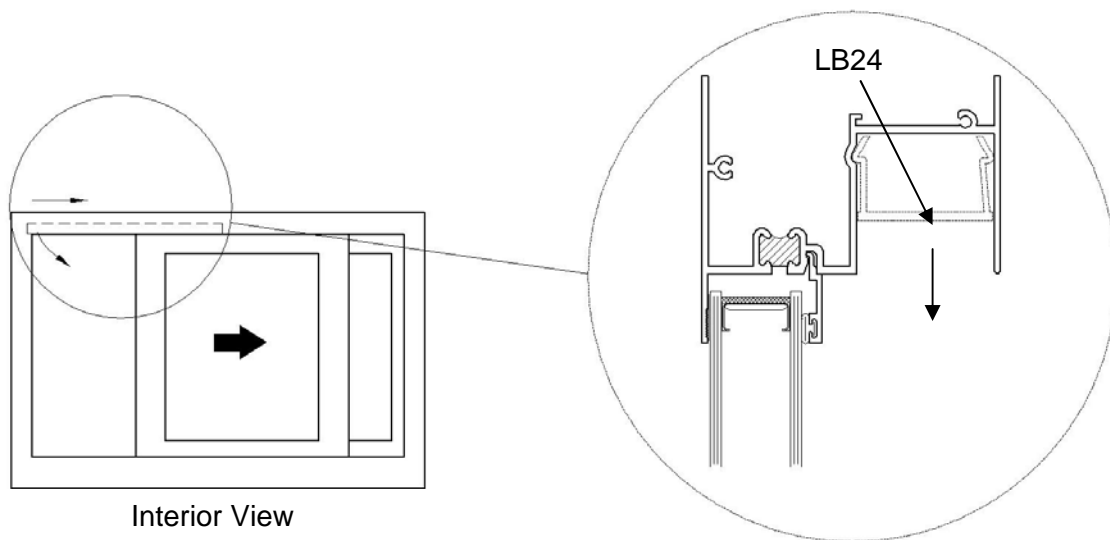

- Remove sash by centering it on the frame then lifting it up into the head and pulling the bottom of the sash out.

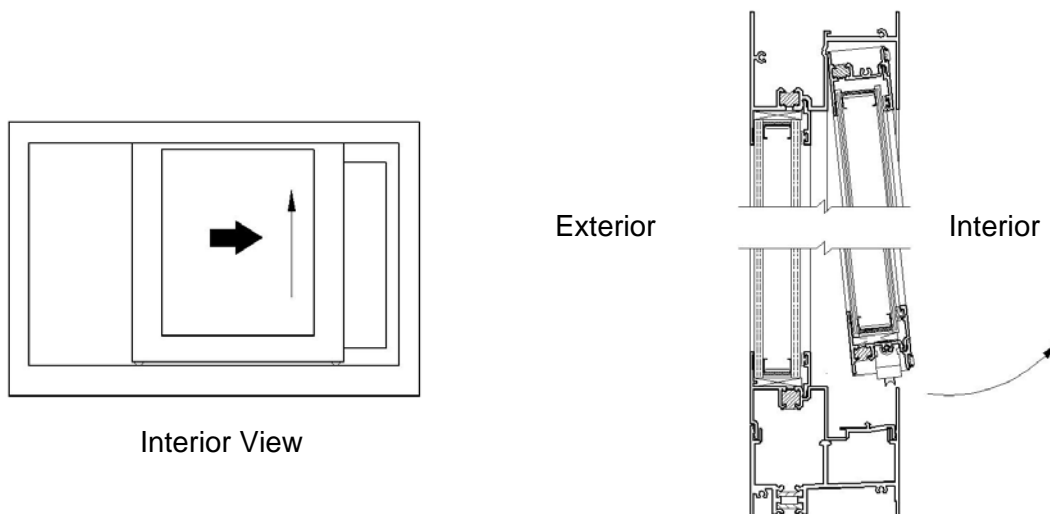

- Reinstall by reversing procedure.

Completely read the General Installation Instructions and all other sections which pertain to your project before starting work. These recommendations are for general erection procedures only. For actual job conditions, see the details on the shop drawings. For perimeter anchor types and spacing, refer to the approved shop drawings or consult the project design professional.

General Installation Instructions for Casement Windows

⚠ A casement window must be installed plumb and secure. All hinges must be securely blocked and anchored to the window opening or mullions through the hinge leaves or as close as possible to the hinges. **⚠**

1. Before installing the casement window, field drill through the window frame at the two unused holes in the hinge.
2. Set the window in position as shown on the approved shop drawings. Apply blocking at hinge points and other anchorage locations to stabilize the frame in a plumb and level position.

The weight of the vent must be supported during the installation process. Apply blocking prior to opening the vent. Opening the vent may cause the jambs to deflect or rack if they are not solidly blocked.

3. Open the vent and match drill hinge supports and blocking at the hinge anchorage holes. Run 1/4" fasteners through the frame, hinge, hinge support, and blocking, and into the surrounding condition. Repeat for each hinge.

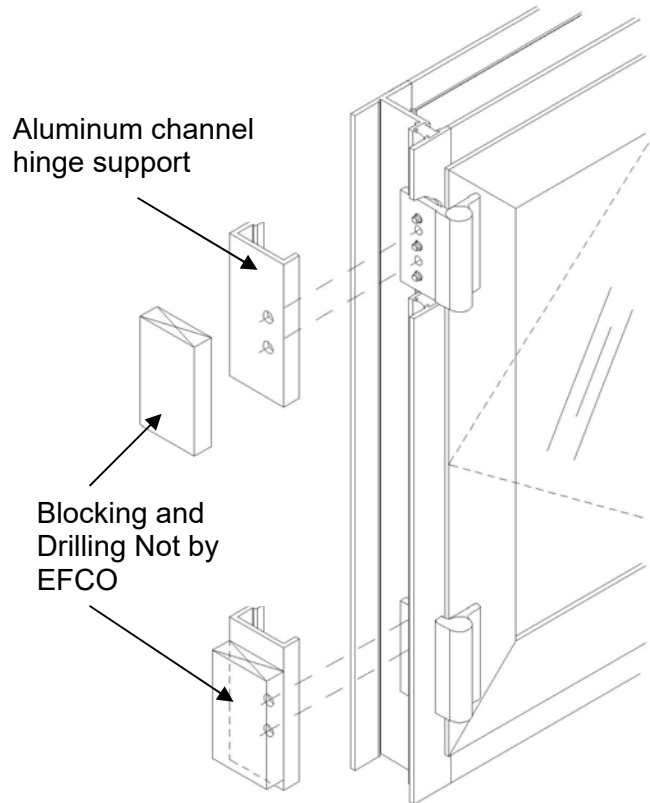

Typical casement hinge anchorage at window mullion

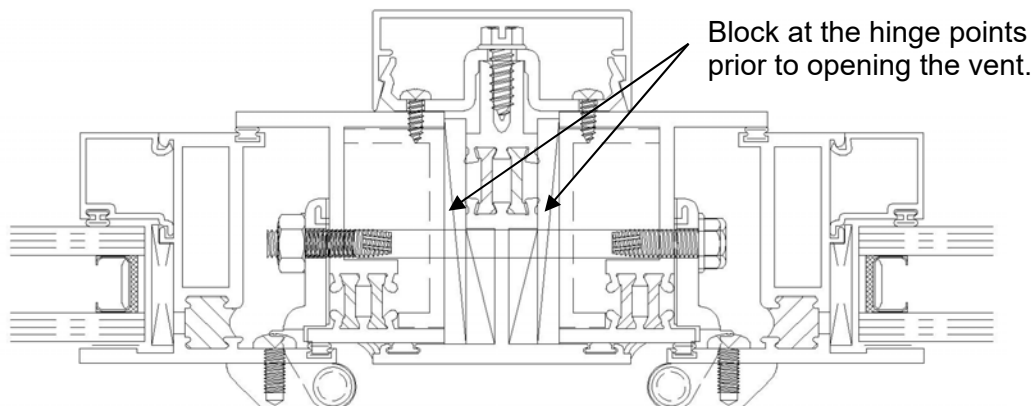

Through bolt supplied by EFCO. Drilling of mullions, frames, and support materials or notching of glazing hooks Not by EFCO.

Completely read the General Installation Instructions and all other sections which pertain to your project before starting work. These recommendations are for general erection procedures only. For actual job conditions, see the details on the shop drawings. For perimeter anchor types and spacing, refer to the approved shop drawings or consult the project design professional.

Typical Hinge Anchorage at Fixed to Vent Stack Joint

Through bolt supplied by EFCO. Drilling of frames and support materials or notching of glazing hooks Not by EFCO.

EFCO Corporation will not be held liable or accept responsibility for damage to the glazing beads, window finish, or broken glass which is a result of this type of installation.

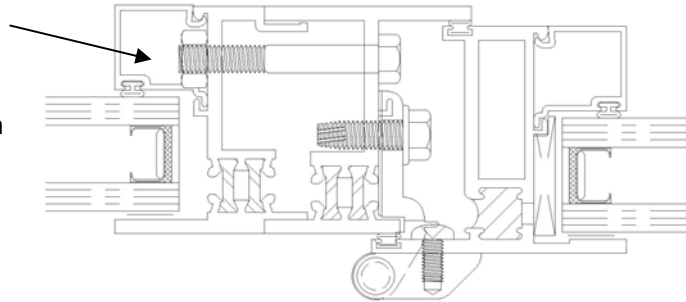

A casement window must be installed plumb and secure. All hinges must be securely blocked and anchored to the window opening or mullions through the hinge leaves or as close as possible to the hinges.

Typical Hinge Anchorage at Vent to Vent Stack Joint

Through bolt supplied by EFCO. Drilling of frames and support materials or notching of glazing hooks Not by EFCO.

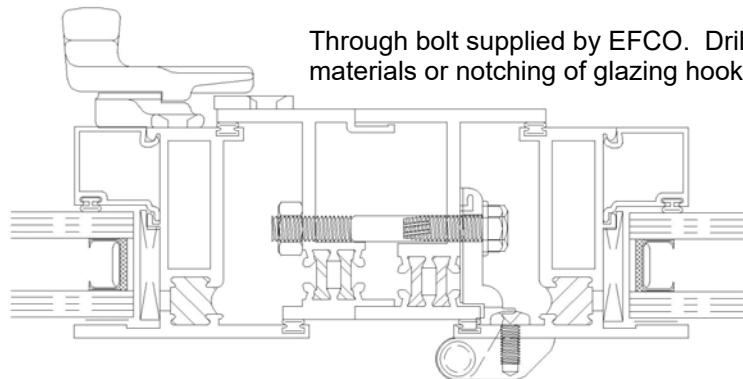

Typical Hinge Anchorage at Subjamb

Perimeter fasteners are Not by EFCO. Drilling of frames and support materials or notching of glazing hooks Not by EFCO.

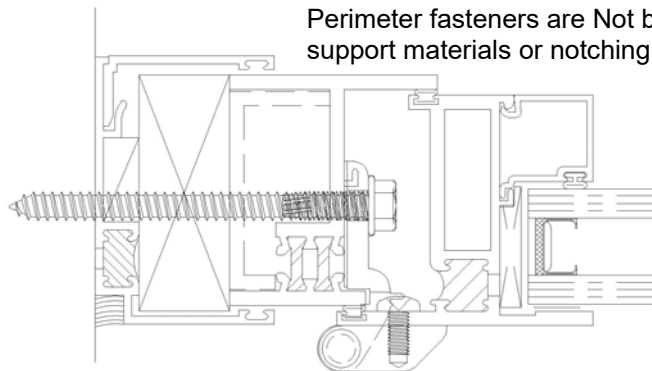

Completely read the General Installation Instructions and all other sections which pertain to your project before starting work. These recommendations are for general erection procedures only. For actual job conditions, see the details on the shop drawings. For perimeter anchor types and spacing, refer to the approved shop drawings or consult the project design professional.

Special Hardware Adjustment if the Casement has Lift Locks

Check and adjust keeper location after anchorage is completed.

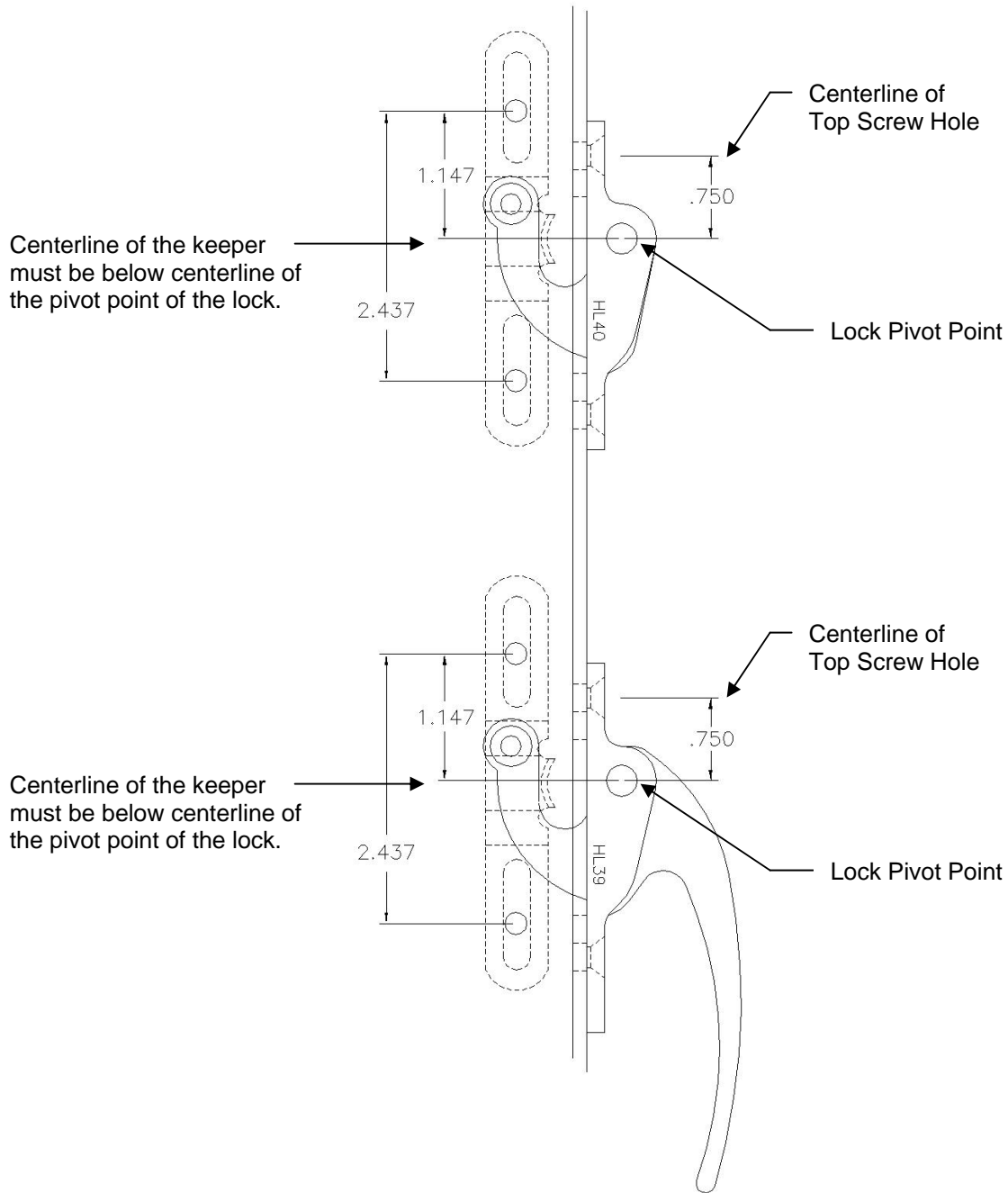

Completely read the General Installation Instructions and all other sections which pertain to your project before starting work. These recommendations are for general erection procedures only. For actual job conditions, see the details on the shop drawings. For perimeter anchor types and spacing, refer to the approved shop drawings or consult the project design professional.

General Installation Instructions for Pivot Windows

1. Install the frame plumb, level, and true. Maintain a consistent frame to vent gap for both height and width. The sash may be removed while installing the frame, at the installer's discretion. However, the weight of the sash must not rest on the weather-strip and the sash must be returned to the frame from which it was removed.
2. All pivot windows are to be blocked and anchored as detailed on the project shop drawings in order to prevent the jambs from bowing or twisting. The window dimension at midpoint shall be within 1/16" of the window dimension at the head and/or sill.

Note:
Vertically pivoted units must be solidly blocked at the sill pivot point to support the entire weight of the sash.

Horizontal pivoted units must be solidly blocked at the extreme sill to jamb intersection to support the dead load weight of the sash being transferred to the jambs.

3. Jack screws in the frame of the pivots are to be adjusted to provide a consistent gap between the sash and frame for proper sweep seal operation. (Jack screws do not replace blocking.)

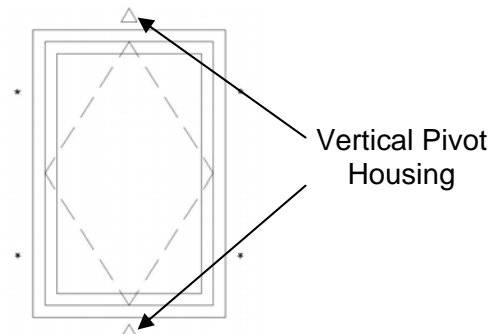
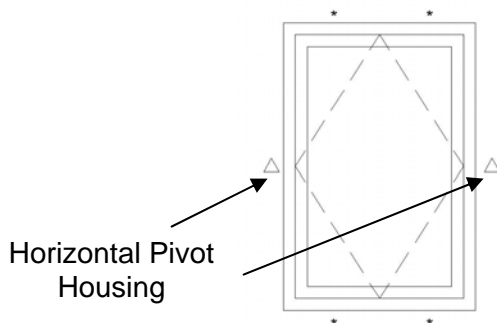
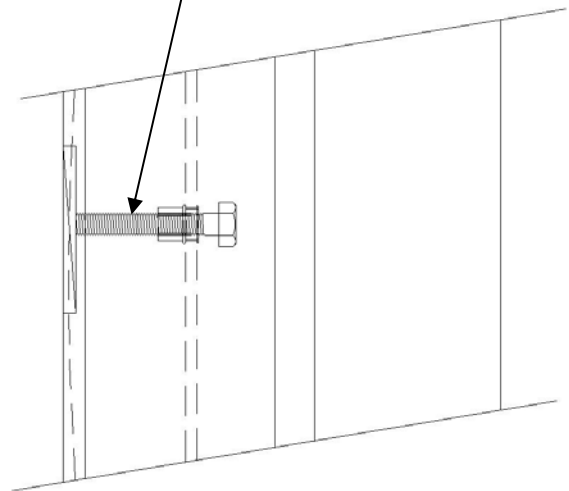
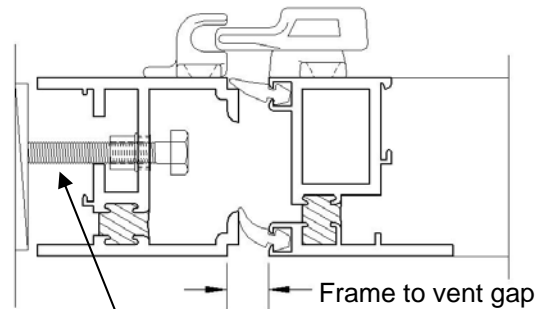

Completely read the General Installation Instructions and all other sections which pertain to your project before starting work. These recommendations are for general erection procedures only. For actual job conditions, see the details on the shop drawings. For perimeter anchor types and spacing, refer to the approved shop drawings or consult the project design professional.

General Installation Instructions for Panning Frames

Typical panning material is shipped factory cut to size and fabricated to fit the exact window dimension. The perimeter flange of the panning is to be field trimmed to fit the masonry opening.

Window, panning frames, and accessories will have the same mark designation.

1. Field assemble the panning frame with supplied pan head screws.
2. Determine the correct panning placement in the opening. EFCO Corporation's combination of panning, window, and trim is provided to entirely cover the old tear out. Refer to the shop drawing details for correct panning placement in order to allow for correct coverage.
3. Determine the exact panning sill face dimension by adding together the sill drop plus the "x" dimension (see page 3 of this Section) and rip down the flange of the sill panning.
4. Determine the required panning frame height, and cut any excess (if required) from the panning head. If additional coverage is required, panning extenders can be furnished.
5. Determine the required panning width and remove excess equally from both panning jambs (if required). If additional coverage is required, panning extenders can be furnished.
6. Use silicone sealant to cover all screw heads and all panning frame joints on the non-exposed side of the panning.

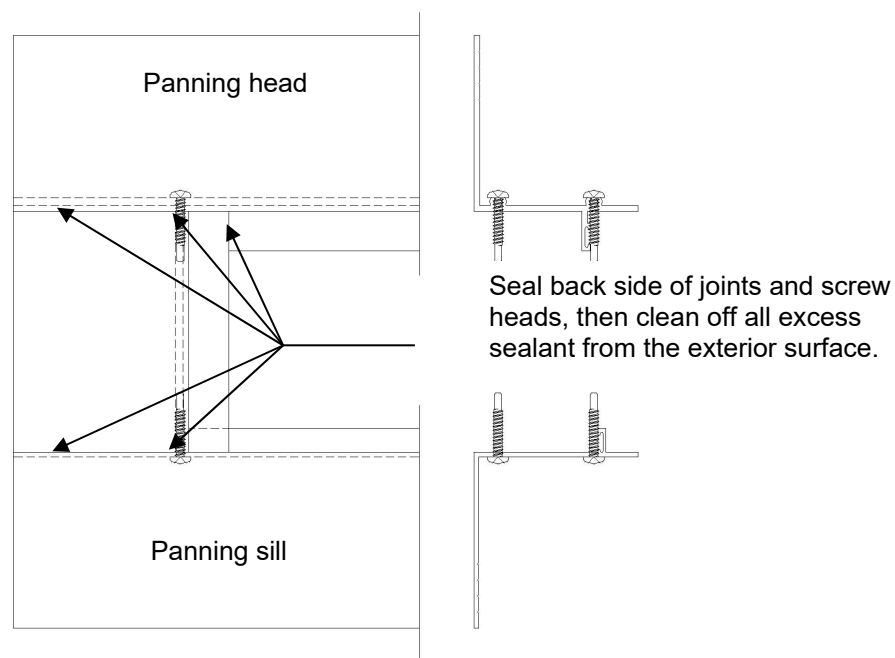

Completely read the General Installation Instructions and all other sections which pertain to your project before starting work. These recommendations are for general erection procedures only. For actual job conditions, see the details on the shop drawings. For perimeter anchor types and spacing, refer to the approved shop drawings or consult the project design professional.

7. Pull the panning frame into the opening from the exterior. Make sure the interior trim will cover all exposed interior perimeter conditions before anchoring the panning.
8. Attach the entire panning perimeter square, plumb, and level into the opening at 16" on center with attachment screws by others. All blocking, sealants, and perimeter fasteners are Not by EFCO. If mullions are required, refer to the mullion installation sheet 5 of this Section.

Anchor spacing may need to be reduced depending on design pressure and anchorage conditions. For perimeter anchor type and spacing, refer to the approved shop drawings or consult the project design professional.

9. Caulk the perimeter of the pan frame to the surrounding masonry opening. Back bed the panning vinyl with sealant just before insertion of the window, or cap seal the window to the panning frame joint from the exterior after the frame is installed. Whichever method is used, the window must be wet sealed to the panning. The panning vinyl is not an adequate weather seal.
10. Set the exterior sill leg of the window onto the sill of the panning frame. Then push the window head and jamb in against the panning head and jamb. Make sure that the window head and jamb legs snap-in securely behind the panning frame clips. This is extremely important! The window must be pushed tight against the panning for the clips to snap-in.
11. Install the interior trim clips. Start by attaching the first clip approximately 6" from each corner, then every 16" on center around the entire window perimeter. Attach the clips to the window with EFCO STT6 screws and to the opening with the erector furnished anchors. Drilling holes in the clips is Not by EFCO. The interior trim clips provide the structural support for the window unit. Each clip must be attached to both the window and the condition to hold the window in the opening.

Anchor spacing may need to be reduced depending on design pressure and anchorage conditions. For perimeter anchor type and spacing, refer to the approved shop drawings or consult the project design professional.

12. All interior trim covers are sent long to be cut to size in the field. Horizontal interior trim covers run through unless noted otherwise on the shop drawings. To install, first measure the interior horizontal opening width and cut the horizontal trim covers accordingly, the snap-in place.
13. Measure between the horizontal trim covers, then cut the vertical trim covers to the proper length. Snap the vertical trim covers into place.

Completely read the General Installation Instructions and all other sections which pertain to your project before starting work. These recommendations are for general erection procedures only. For actual job conditions, see the details on the shop drawings. For perimeter anchor types and spacing, refer to the approved shop drawings or consult the project design professional.

TYPICAL PANNING INSTALLATION - HEAD AND SILL CONDITION

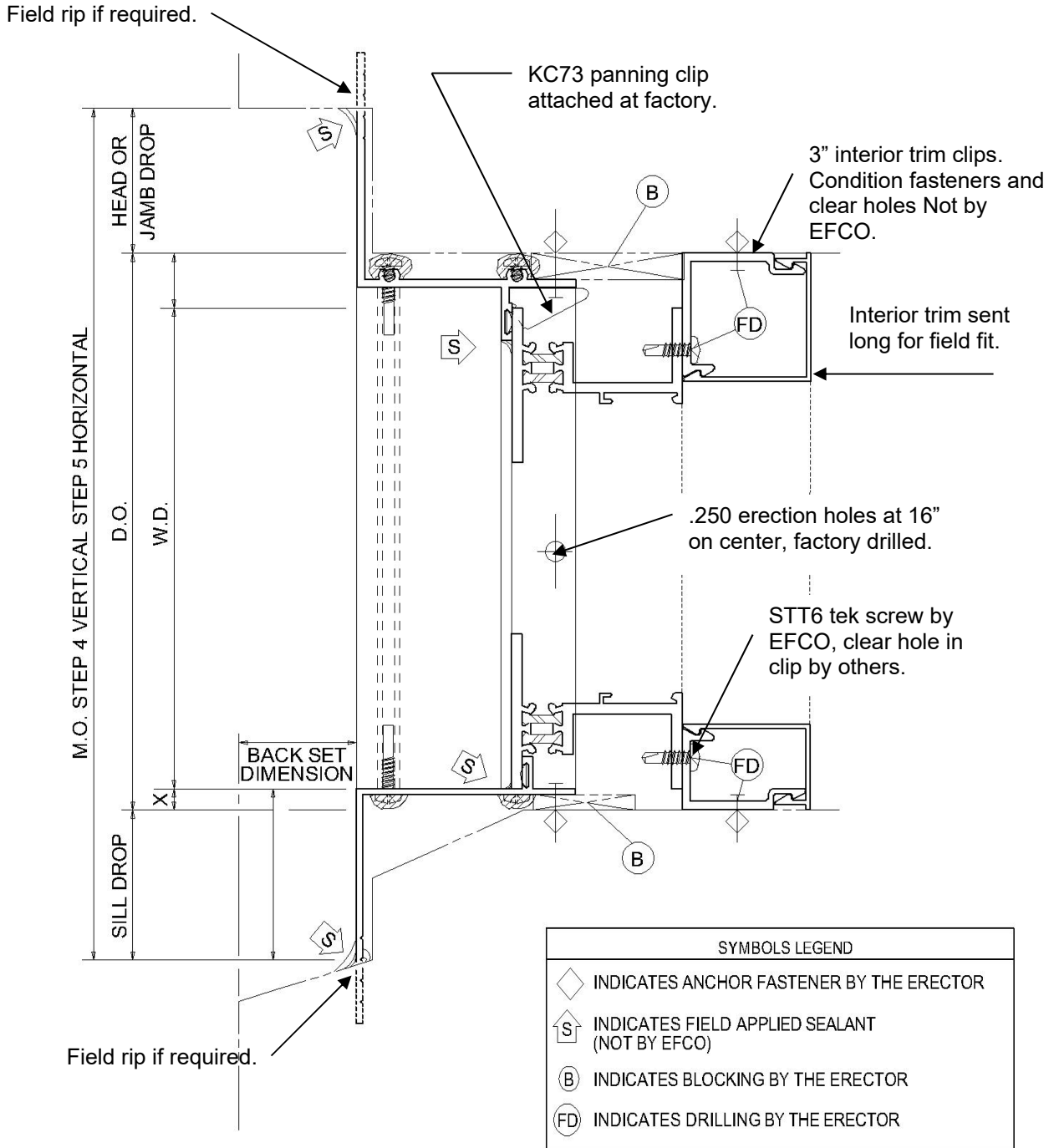

Completely read the General Installation Instructions and all other sections which pertain to your project before starting work. These recommendations are for general erection procedures only. For actual job conditions, see the details on the shop drawings. For perimeter anchor types and spacing, refer to the approved shop drawings or consult the project design professional.

Typical Jamb Condition

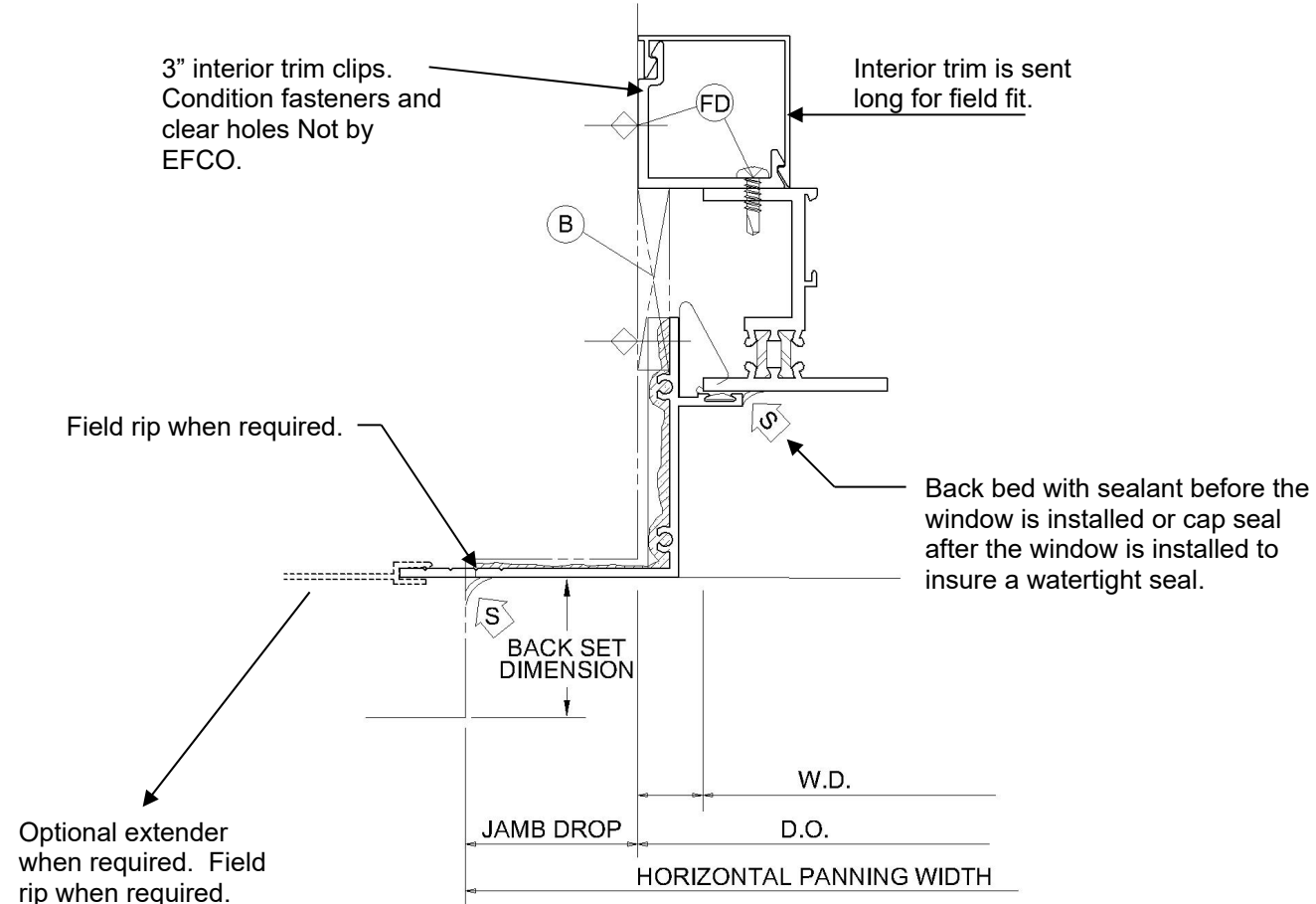

Reference the Basic Window Installation Section, Page 8 of 10, for additional information on extender assembly.

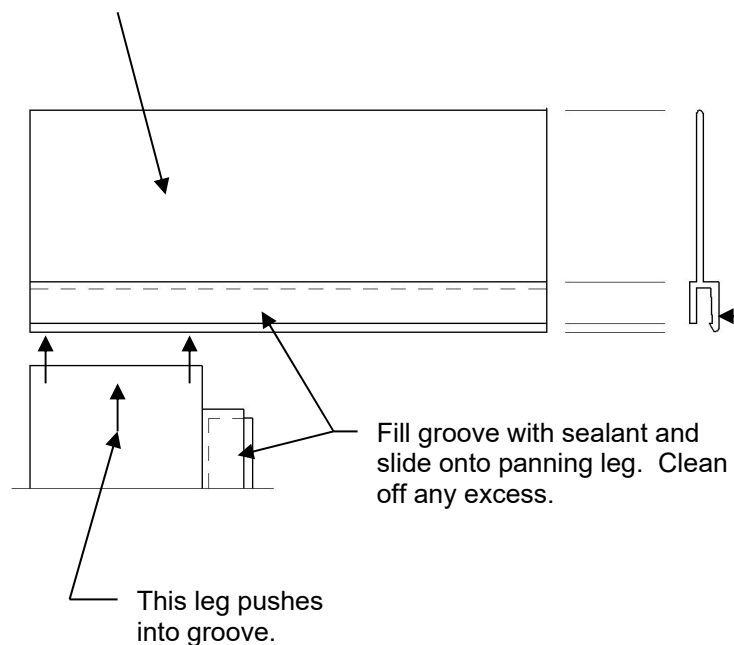

Typical Extender Corner
 If extenders run vertical and horizontal EFCO will cut to fit.
 If extenders run one direction only, they will be sent long for field cut.

Completely read the General Installation Instructions and all other sections which pertain to your project before starting work. These recommendations are for general erection procedures only. For actual job conditions, see the details on the shop drawings. For perimeter anchor types and spacing, refer to the approved shop drawings or consult the project design professional.

Mullion Installation in Panning

1. First complete steps 1 to 9 on Typical Panning Installation pages 1 and 2 of this Section.
2. Refer to the shop drawing for the correct position of the mullions.
3. Set the mullion into the panning frame. Plumb the mullion to the opening. Fasten the mullion to the opening by use of two EFCO supplied mullion installation clips (FDS6). Locate one mullion installation clip at the masonry head and one at the masonry sill. Attach the clips to the opening with erector furnished fasteners, then attach the mullion to the clips with EFCO furnished fasteners.
4. Now follow steps 11 to 14 of the Typical Panning Installation page 2 of this Section.
5. Attach the mullion pressure clips to the mullion as close to the top end as possible, and then 16" on center with EFCO supplied fasteners. Spacing may need to be reduced depending on design pressure and anchorage conditions. Refer to the approved shop drawings or consult the project design professional.
6. Attach the mullion clip to each window jamb with EFCO supplied fasteners. Make sure that the window jamb remains square and plumb. The drilling of the window jambs is Not by EFCO.
7. Field cut the vertical mullion cover to fit between the horizontal trim covers and snap over the mullion clips.

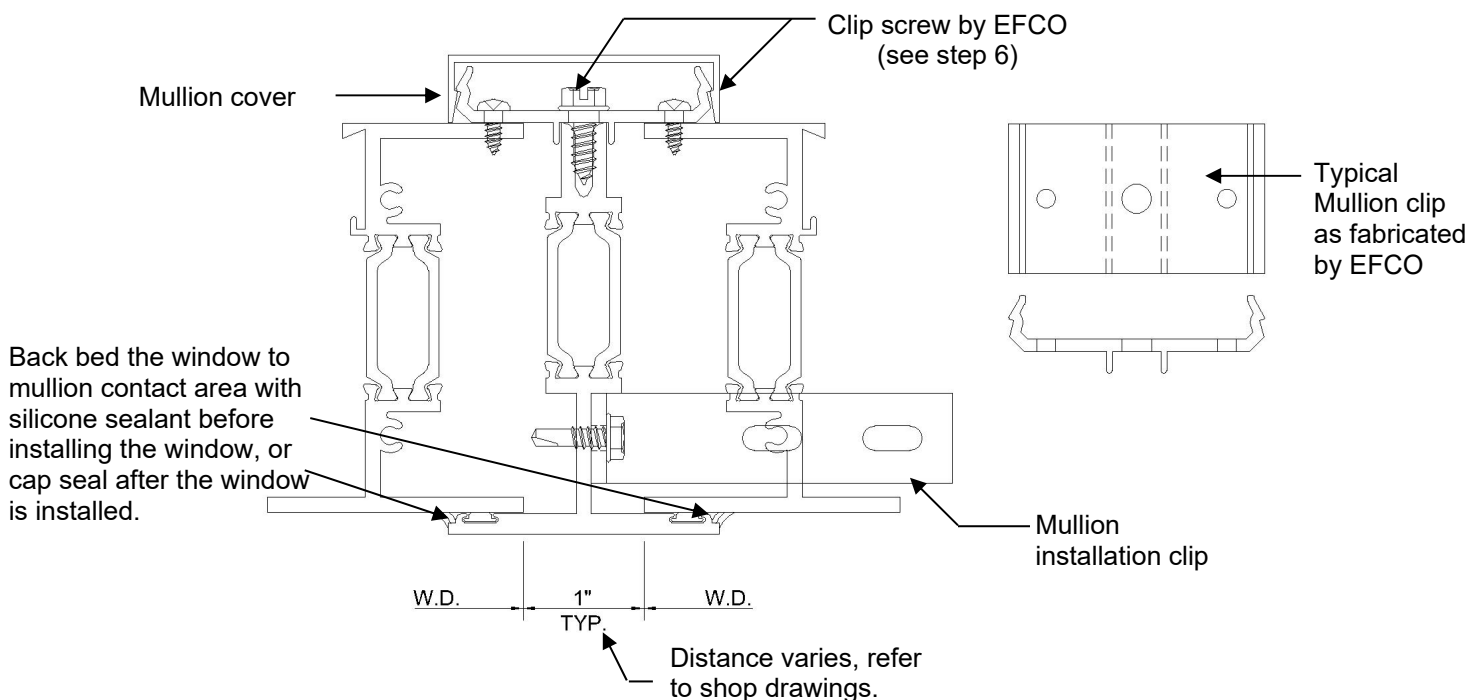

Completely read the General Installation Instructions and all other sections which pertain to your project before starting work. These recommendations are for general erection procedures only. For actual job conditions, see the details on the shop drawings. For perimeter anchor types and spacing, refer to the approved shop drawings or consult the project design professional.

ERECTOR NOTE:

All notching called out by EFCO will be done in the field by the erector on "Express Jobs".

Typical Upper mullion notch by EFCO

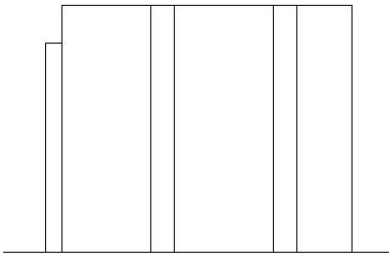

Typical 3 piece mullion by EFCO as shipped on fabricated jobs.

Mullions ship long for field fabrication by the erector on express jobs.

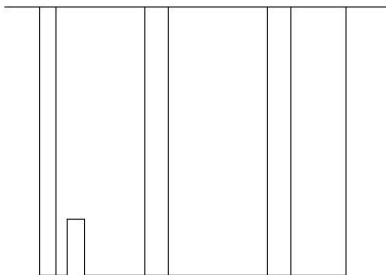

Typical Lower mullion notch by EFCO

Note: Box mullions that extend past the panning may be shipped long for additional field notching by the installer.

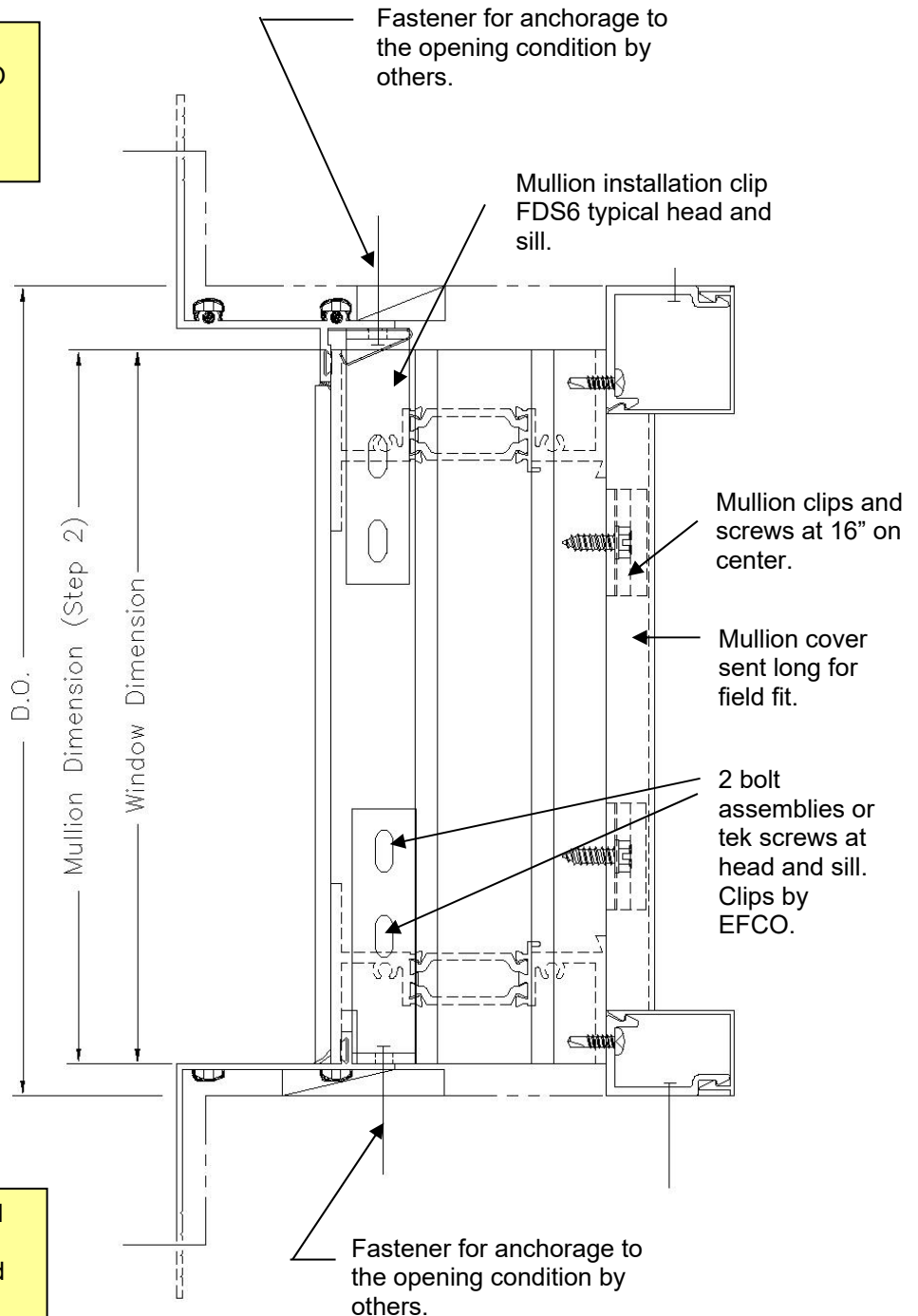

Window Installation Instructions - Typical Subframe Installation Section

General Notes:

- The following field installation instructions are best practice methods based on typical conditions, and must be used in conjunction with shop drawings.
- Some projects may require modifications to the standard procedure which must be coordinated with the shop drawings to maintain system performance.
- See shop drawings for backer-rod/blocking requirements.
- Not By EFCO shown as N.B.E.
- Installer responsibilities (N.B.E) include:
 - All notching on “Express Jobs”.
 - All anchorage clear holes, blocking, sealants, shims, and perimeter fasteners.
- Cut the subsills, subjamb, subheads, and subhead closures to length and when they are installed, make sure they are all plumb, using shimming as necessary.
- Subhead closures must be cut to the same dimension as the subheads.
- The sealing of the subhead and subjamb to the condition is critical to the performance of the assembly and will vary greatly based on the building condition. The location of these seals will be shown on the shop drawings.
- Subhead/Subsill splice joints are typically placed every 16 feet maximum with a 1/2” separation. (Reference approved shop drawings for specifics of job)
- Sealant at splice locations will be non-hardening, skinning sealant.
- Ensure that the sealant overlaps the aluminum surfaces by at least 1/8”.
- Closure splices should be at a different location than the subhead, using a similar backer material and sealant application.
- Notching of mullion and covers at subhead and subsill may be required to meet project conditions (see shop drawings for details).
- For perimeter anchor type and spacing, refer to the approved shop drawings or consult the project design professional. All anchorage clear holes, blocking, sealant, and perimeter fasteners are not by EFCO.
- For optimal water performance, ensure that all the subframing is installed level and true, and that all debris is removed from the subframing while installing.
- Seal around all fastener heads at sill with sealant to ensure water tight seal. Tool the sealant around the fastener heads so that the sealant makes contact with the surface of the subframe.
- Typically EFCO will send subjamb long for field fit. The sill end of the subjamb may have some type of notch cut by EFCO when required.
- When the subjamb comes pre-notched at the sill end, all length adjustment should be done to the head end.

Window Installation Instructions - Typical Subframe Installation Section

Subsill Preparation Prior to Installation:

Ensure that there is sealant over the entire strut surface and tool into place.

Drill 1/4" diameter weep holes 6 inches from each end (not to exceed 5 feet on center).

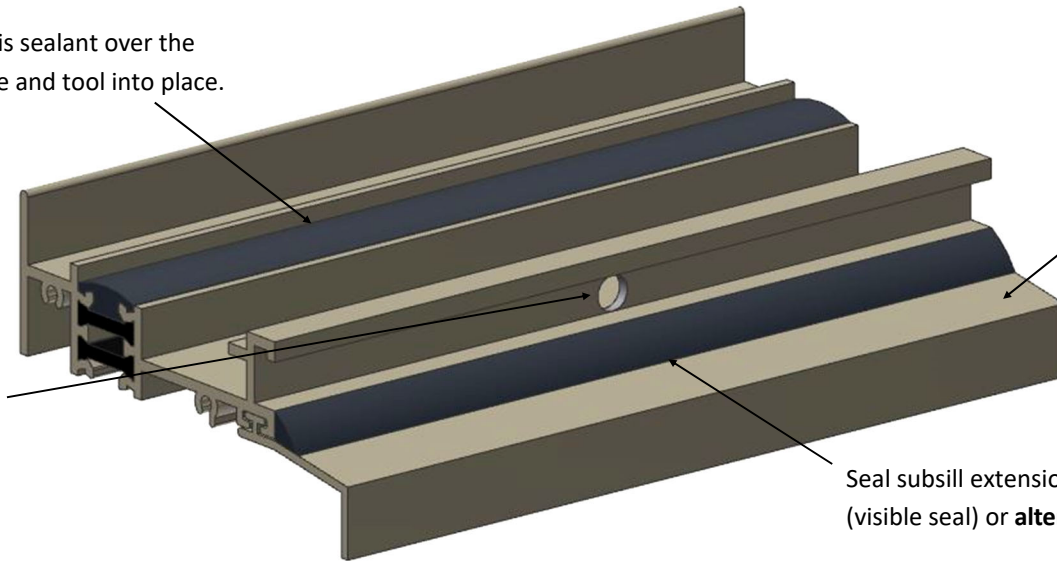

Subsill extension: Check the opening condition and shop drawings to verify that no special notches in the extender are required.

Seal subsill extension: using **preferred method** (visible seal) or **alternate method** (blind seal).

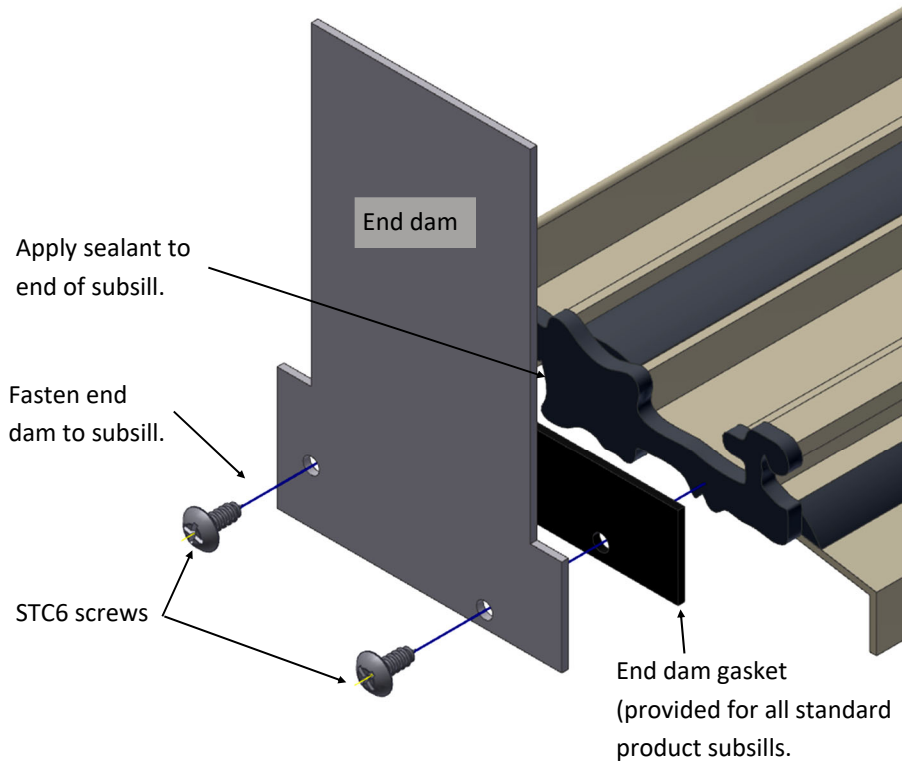

Apply sealant to end of subsill.

Fasten end dam to subsill.

STC6 screws

End dam

End dam gasket
(provided for all standard product subsills).

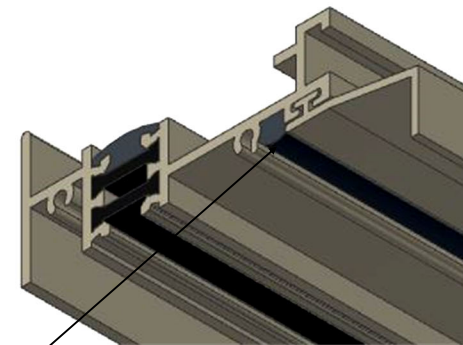

Alternate Method: Blind seal

Note: If you are using the blind seal method, while the sealant is still wet, care must be given to the orientation and handling of the extension in relation to the subsill. The extension should be supported in the desired finished position while the silicone is curing.

Window Installation Instructions - Typical Subframe Installation Section

Subsill and Subhead Splicing Instructions:

Subsill

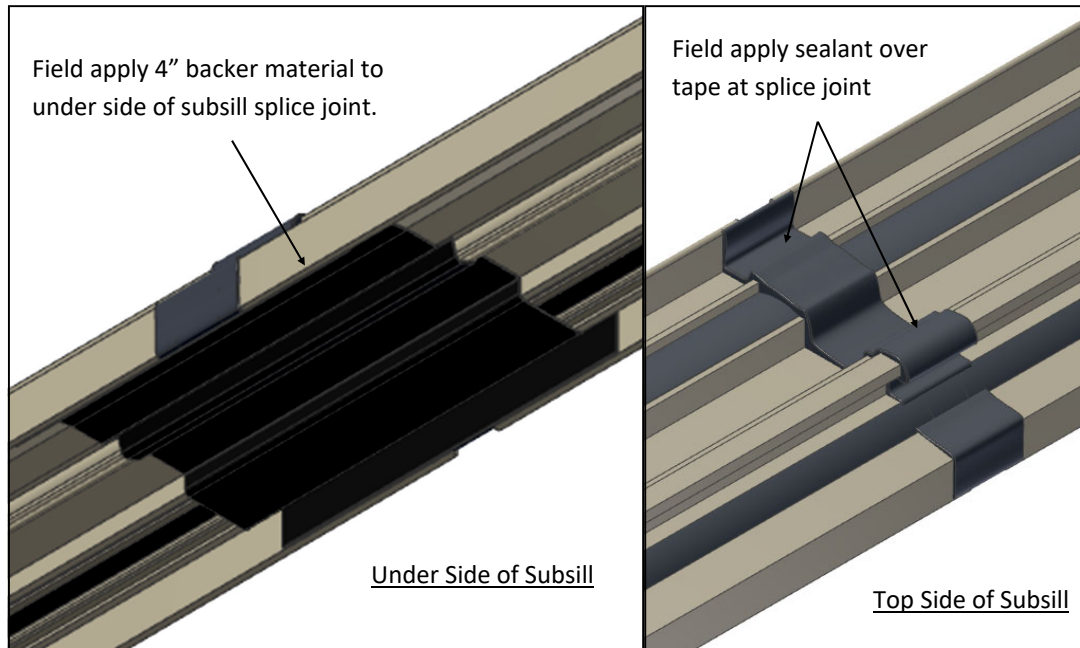
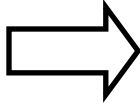

Subhead

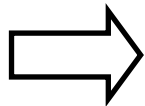

Field apply 4" backer material to under side of subhead splice joint starting above gasket reglet and stopping at closure hook.

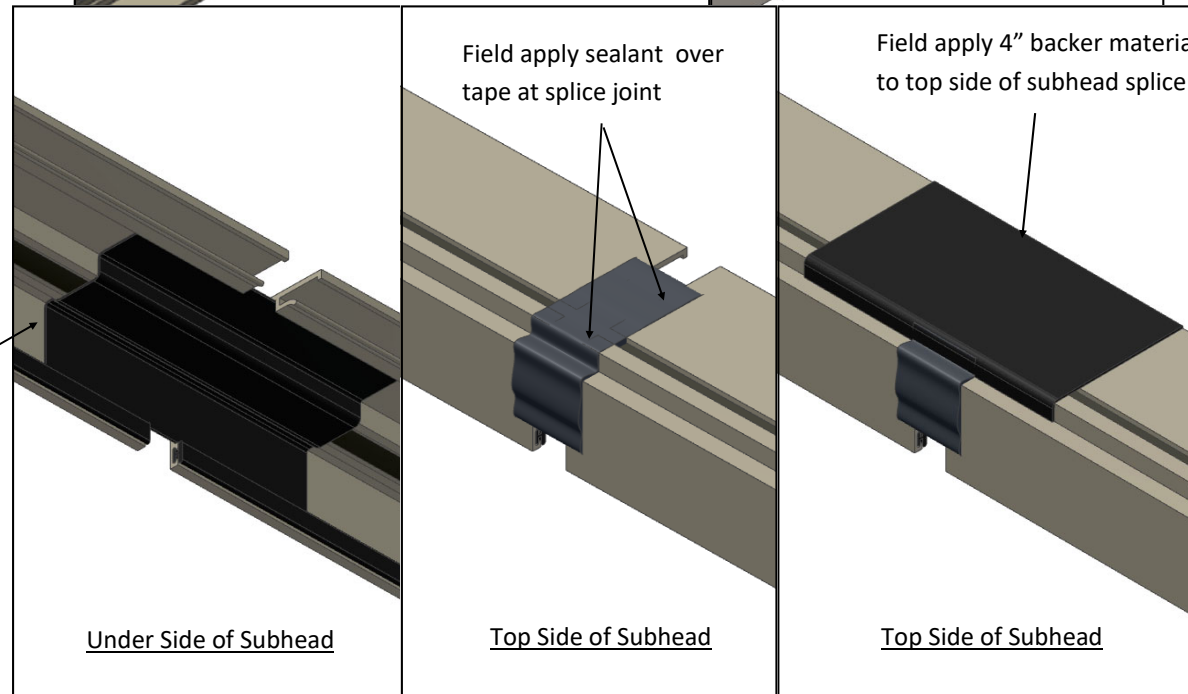

Window Installation Instructions - Typical Subframe Installation Section

Subsill Installation:

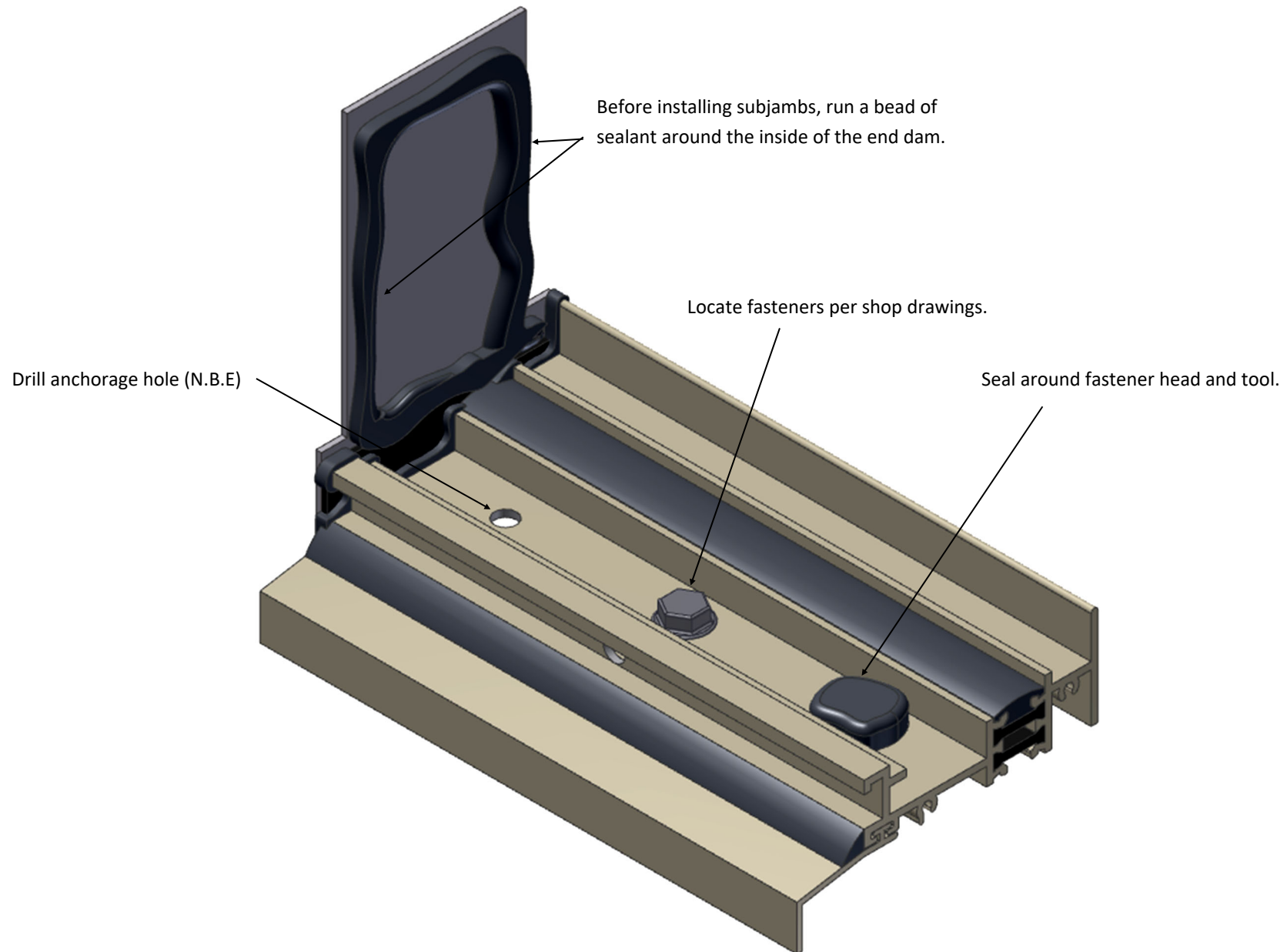

Window Installation Instructions - Typical Subframe Installation Section

Subhead/Subjamb Preparation and Installation:

Note: If subheads and subjamb are not being used, proceed to pg. 13.

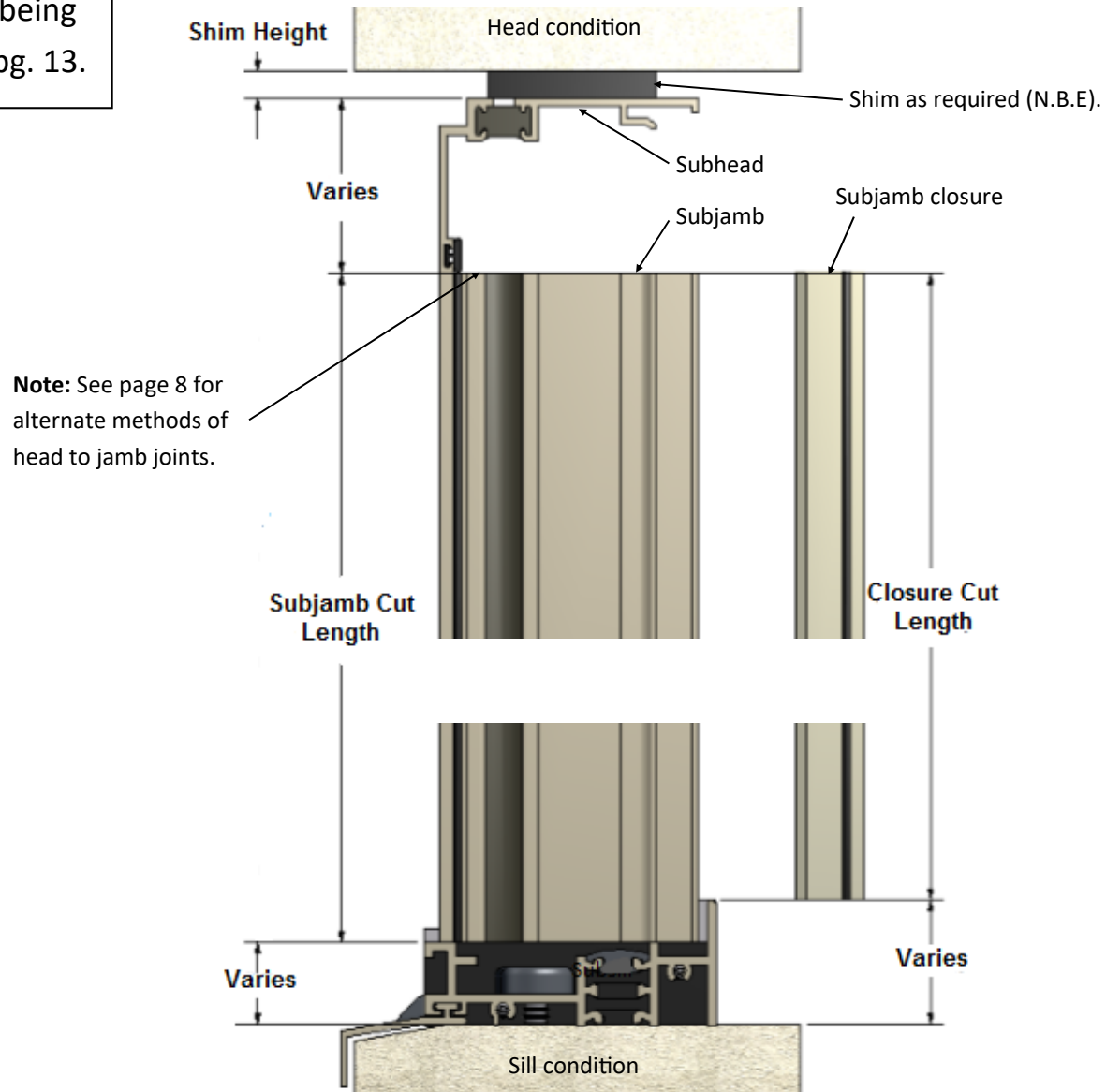

Window Installation Instructions - Typical Subframe Installation Section

Subsill to Subjamb Critical Seal Areas:

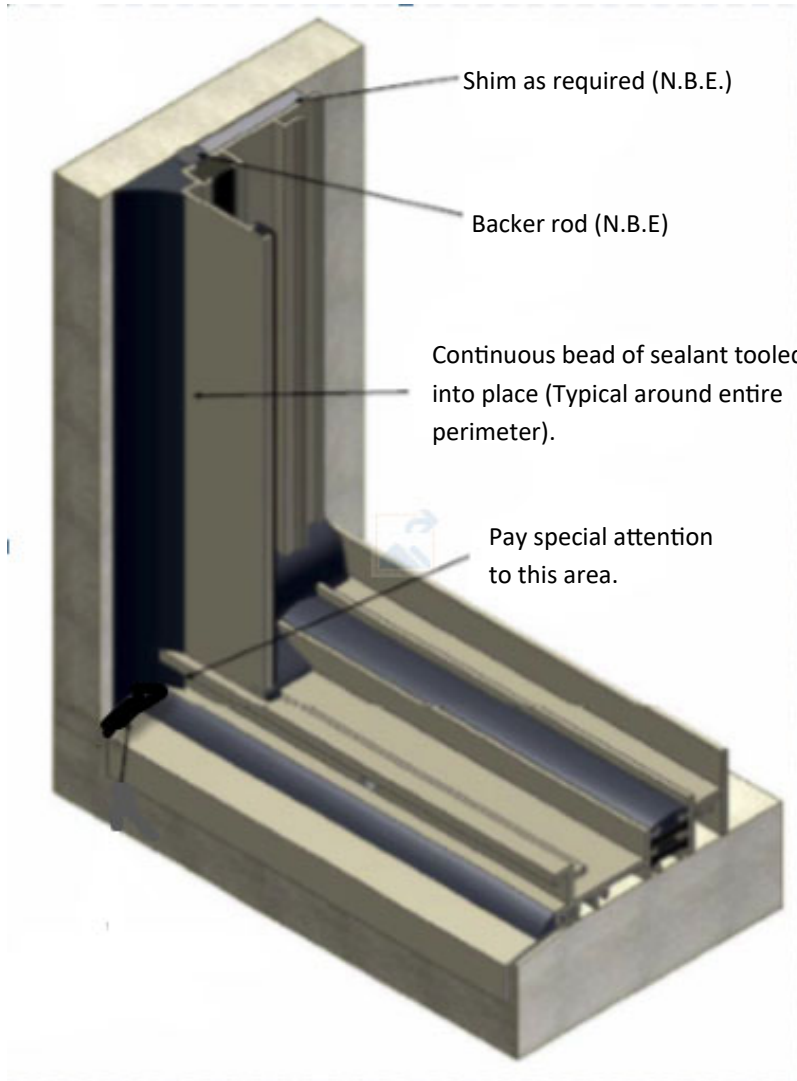

Ensure that sealant covers entire thermal break surface of the subjamb, and marry into subsill sealant.

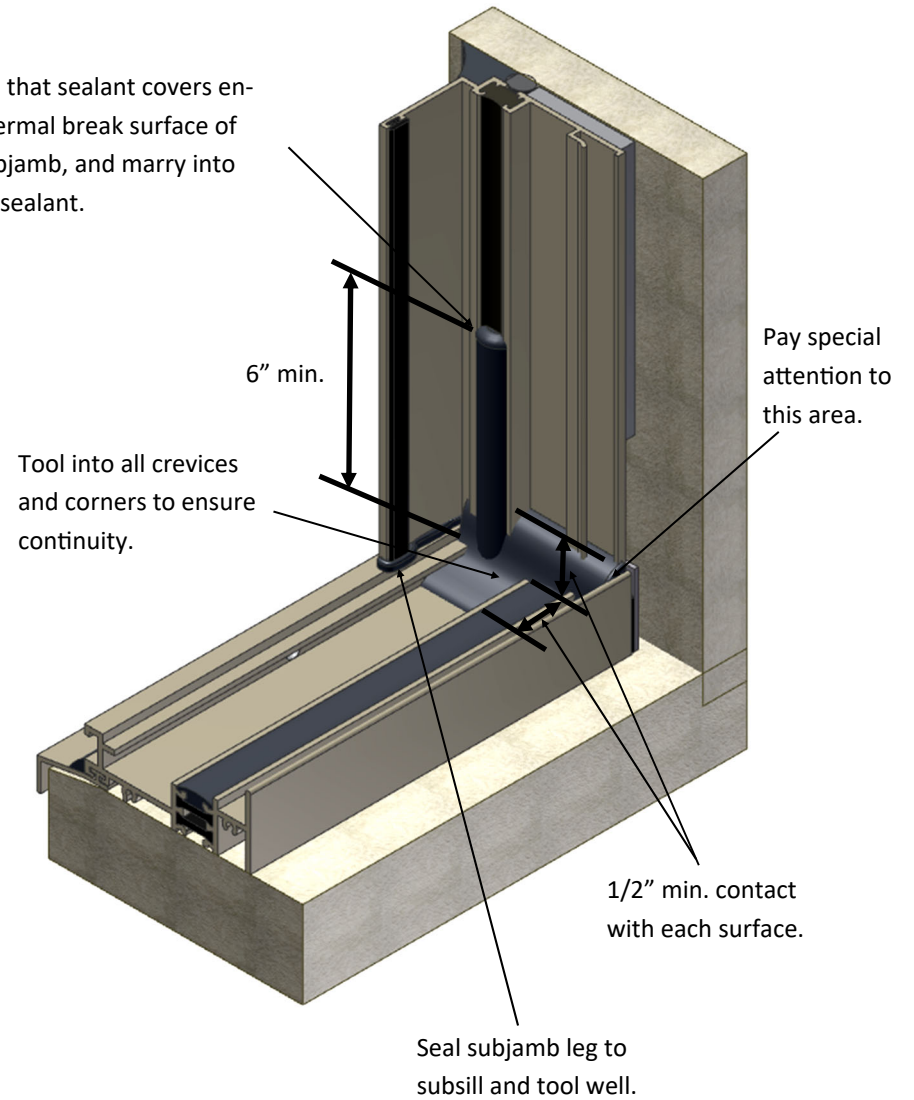

Window Installation Instructions - Typical Subframe Installation Section

Installation of Window Into Subframe:

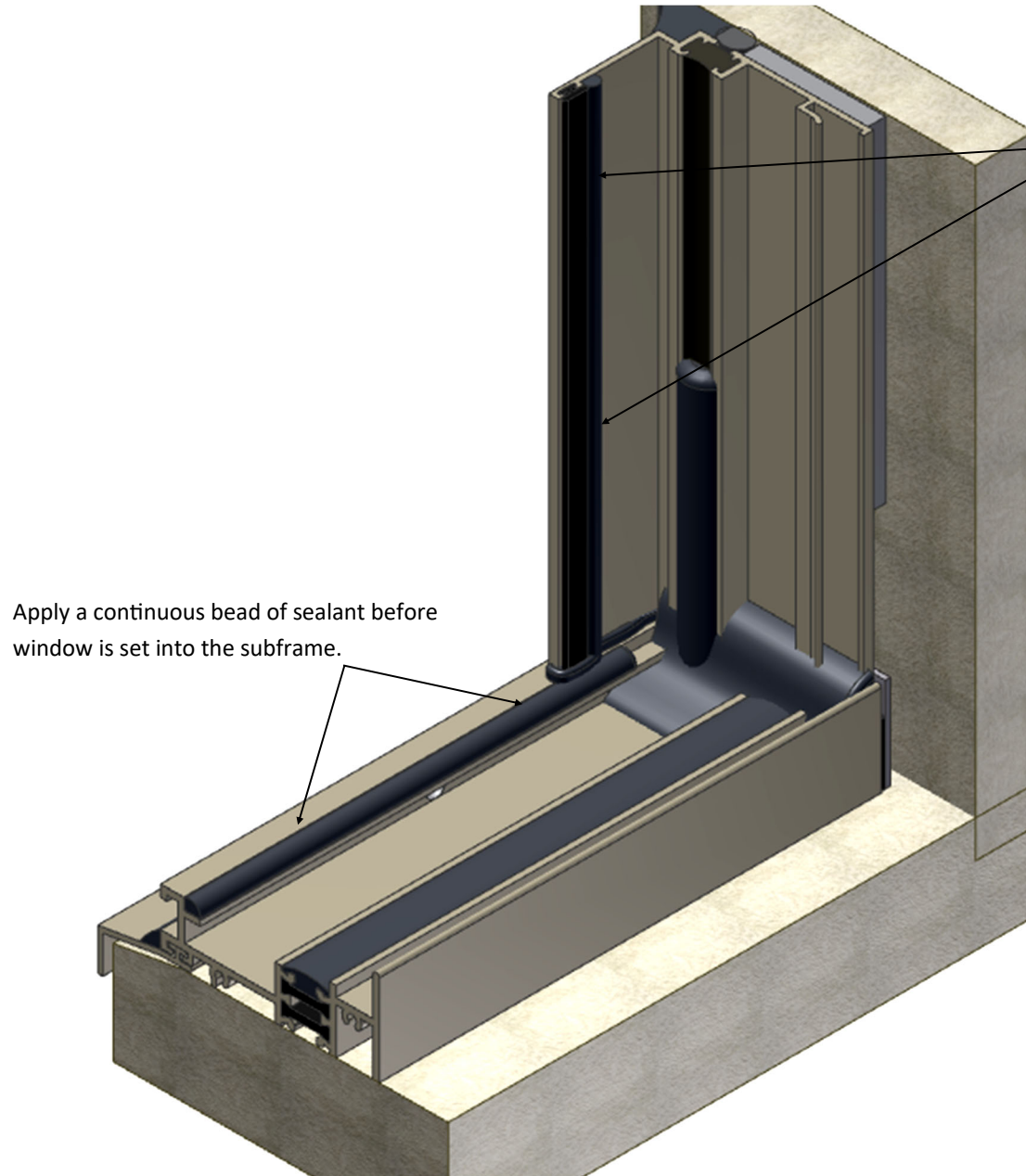

Apply a continuous bead of sealant before window is set into the subframe.

Apply a continuous bead of sealant on the exterior leg of the subjamb and subhead directly behind the gasket reglet. Sealant bead height must be taller than the bulb vinyl.

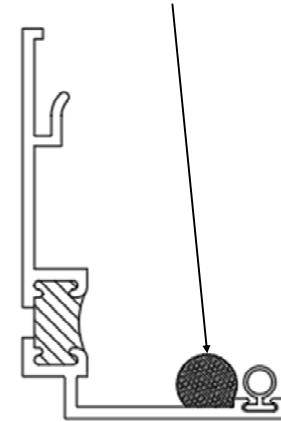

Note: The above step may be left out if, and only if, the subframe to window joint is cap sealed after the window is installed (see page 12).

Window Installation Instructions - Typical Subframe Installation Section

Alternate Methods for Subhead to Subjamb Joinery:

Standard Square Cut Subframe Method

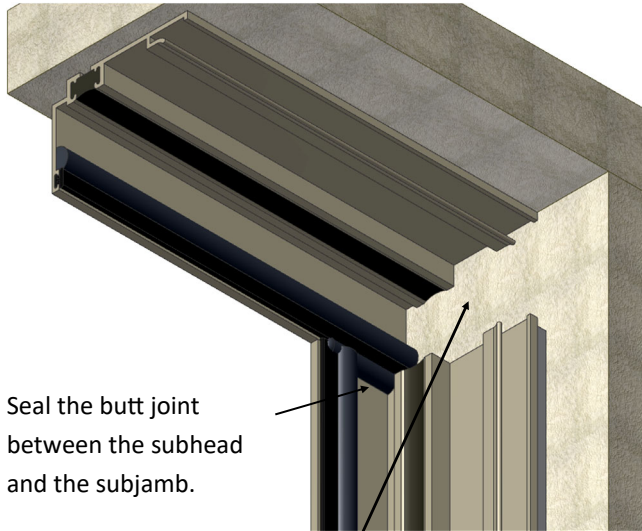

Seal the butt joint between the subhead and the subjamb.

In order to fill these voids use an aluminum end dam, silicone sheet, or plug with a sealant compatible material.

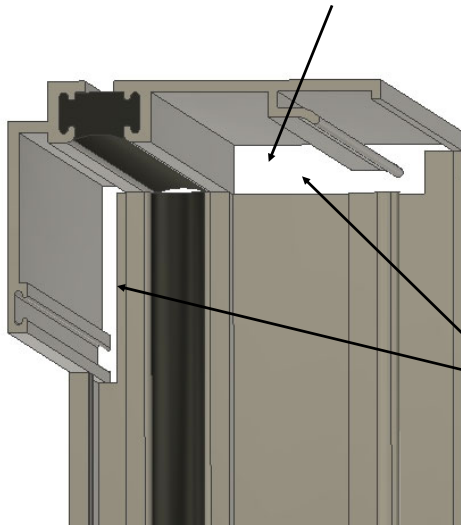

Alternate End Notched Subframe Method

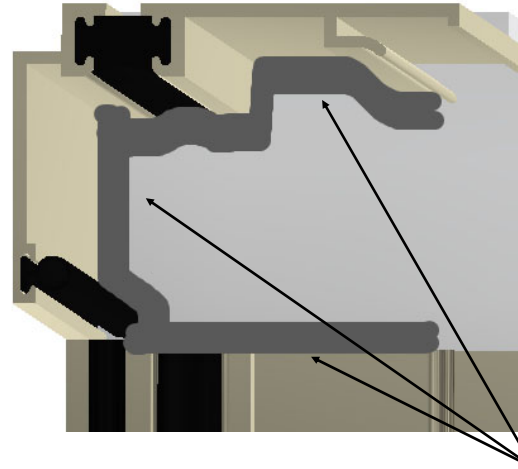

If an EFCO supplied end dam is being used pre-attach to subhead with EFCO supplied tek fasteners before installation.

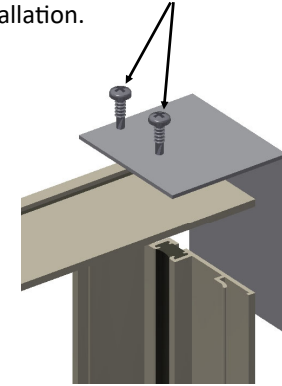

When end dam is used seal joints between the end dam and the subjamb/subhead. Seal from subjamb closure hook to subhead closure hook.

Note: This should be done for both the standard square cut method and for the end notched method.

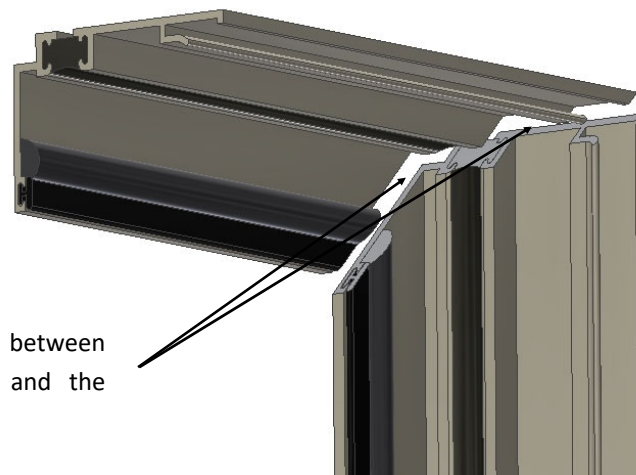

Alternate Mitered Subframe Method

Window Installation Instructions - Typical Subframe Installation Section

Installation of Subsill Drive-In Gasket:

Drive-in alignment dart gasket between window frame and interior leg of subsill. Leave a 2" gap or less between the end of drive-in gasket and the subjamb.

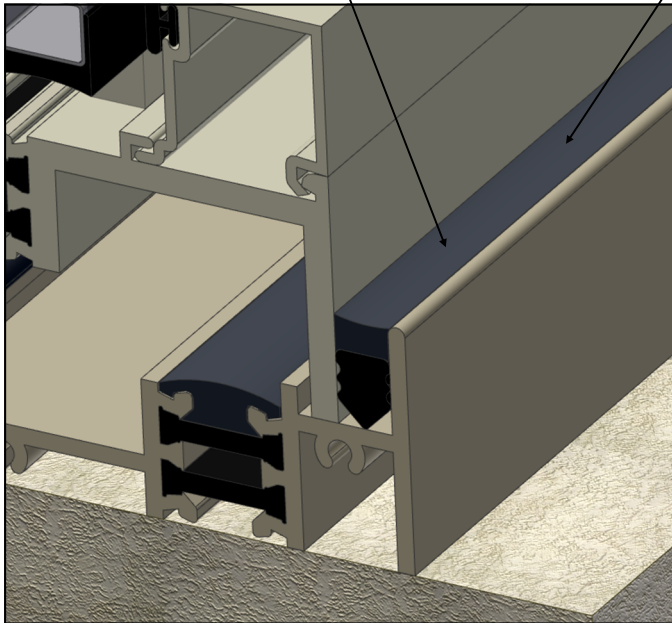

Before installing the subjamb closures, seal over the dart gasket and fill in the gaps at the ends. This seal must be joined with the seal that joins the subjamb and subsill.

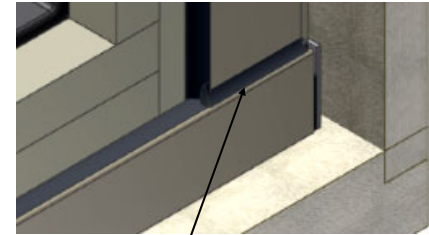

Drive-in wedge gasket over sealant: Cut to fit tight between the subjamb closures.

Note: Fill gap underneath the subjamb closure completely with sealant.

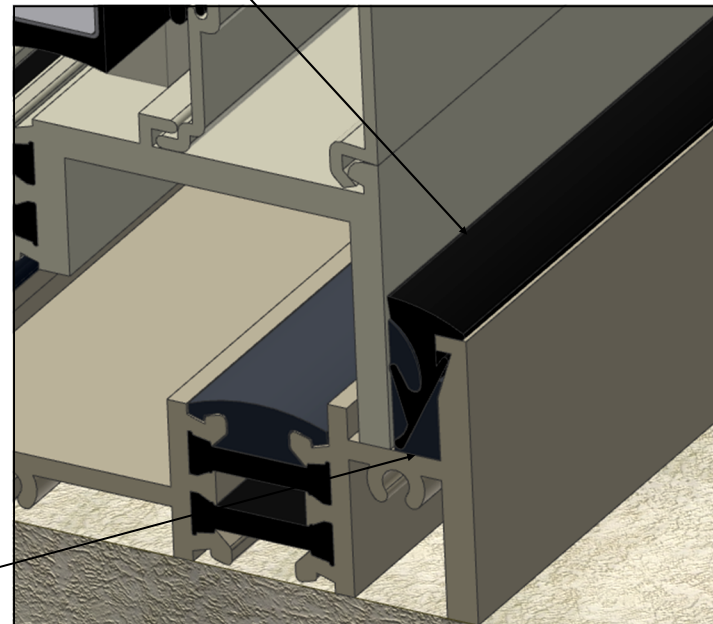

Preferred Method of Installation: Use a Dart

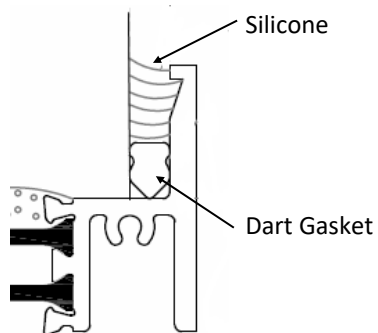

Apply continuous bead of sealant between window frame and interior leg of subsill.

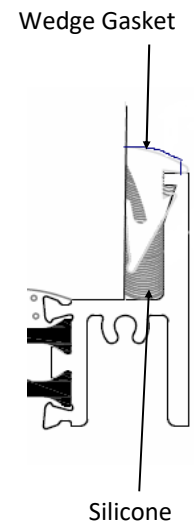

Alternate Method: Use a Drive-In Gasket

Window Installation Instructions - Typical Subframe Installation Section

Installation of Subjamb Closure (Standard Method):

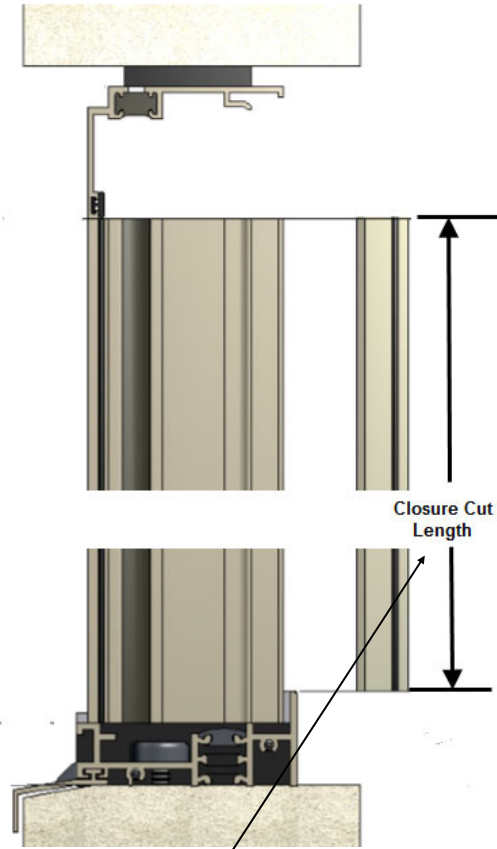

Measure for subjamb closure length.

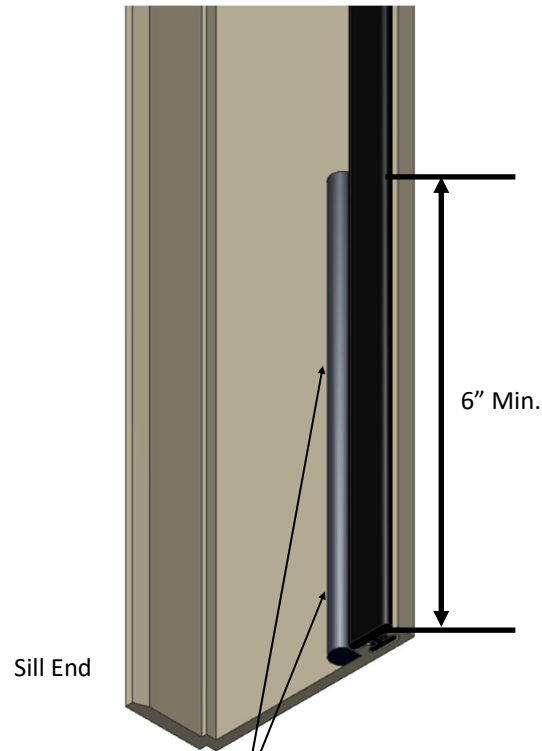
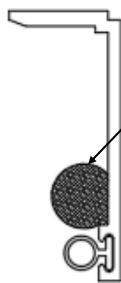

Prepare subjamb closure to seal to window by applying a bead of silicone sealant on the sill end of the subjamb closure, just behind the bulb vinyl. Sealant bead height must be taller than the bulb vinyl.

Note: The above step may be left out if and only if the subframe to window joint is cap sealed after the window is installed (see page 11).

Set subjamb closure in bed of sealant.

Make sure all sealant is married together.

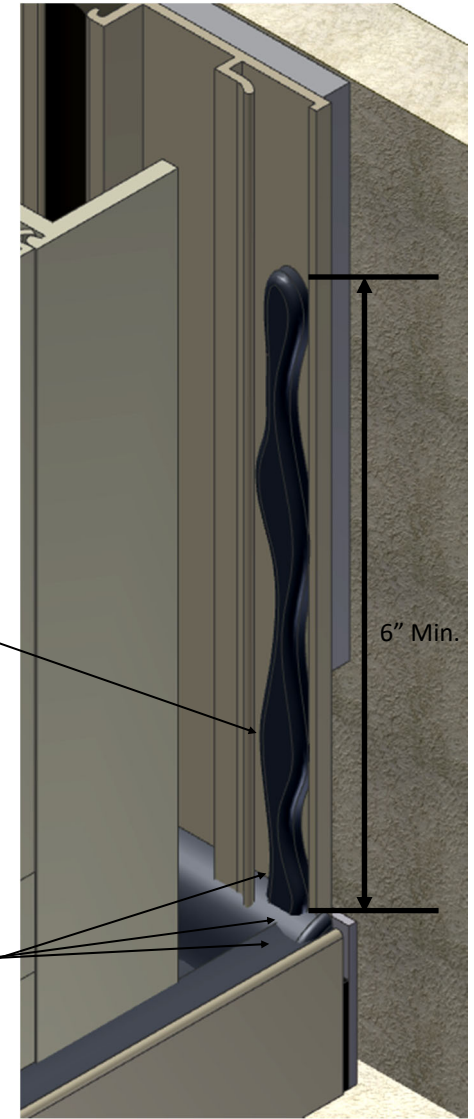

Note: Take care not to over-apply sealant in the track where the closure will snap as this can create a hydraulic action and make the closure difficult to snap in.

Window Installation Instructions - Typical Subframe Installation Section

Installation of Subjamb Closure (Alternate Method):

Cap bead subjamb to window joint a minimum of 6". If desired cap bead can run continuously up the entire length of the subjamb.

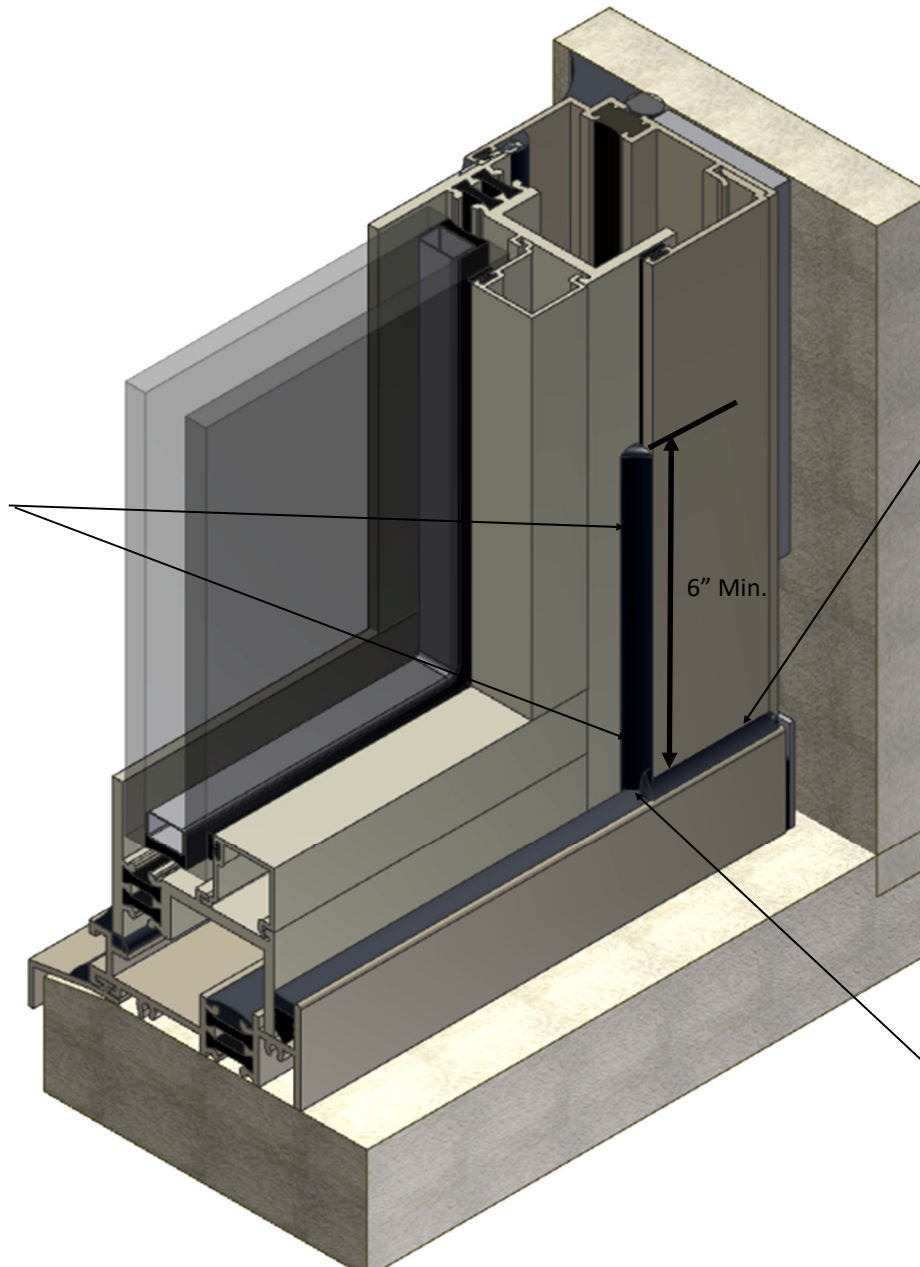

Extend sealant over subsill to subjamb joint. Subjamb closure must be in contact with wet sealant to ensure water tight installation.

Join and tool subjamb and subsill sealant lines.

Window Installation Instructions - Typical Subframe Installation Section

Alternate Exterior Perimeter Seal (Cap Bead):

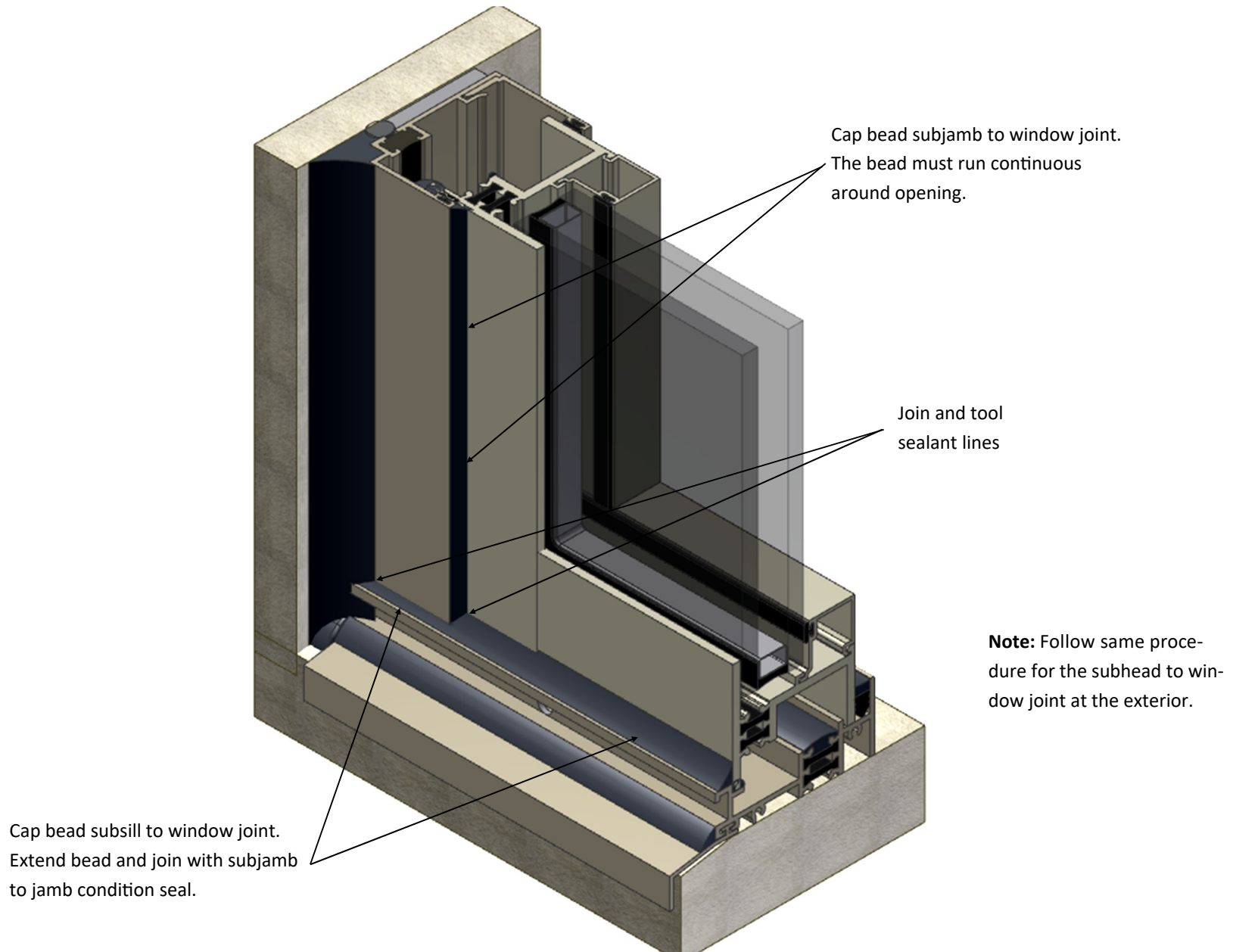

Window Installation Instructions - Typical Subframe Installation Section

Subsill Installation When Subhead/Subjambbs Are Not Used:

Push backer rod into the void between the end dam and the condition.

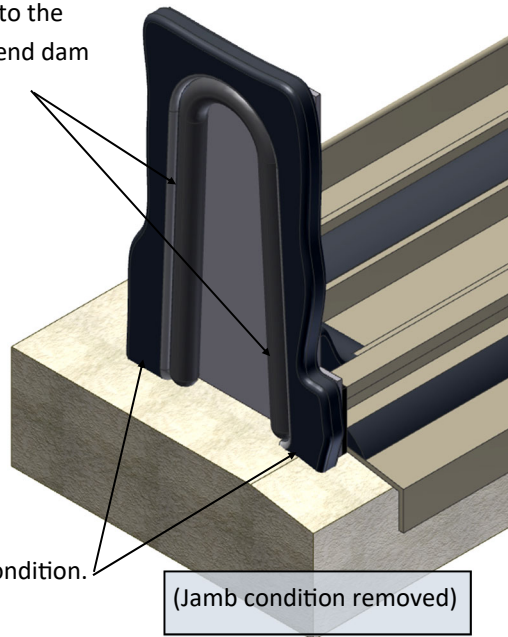

Note: See page 3 for end dam attachment to subsill.

Anchor window to opening as shown on shop drawings.

Install and seal window to subsill as shown on pages 7, 9, and 12.

Seal window to jamb/
head conditions.

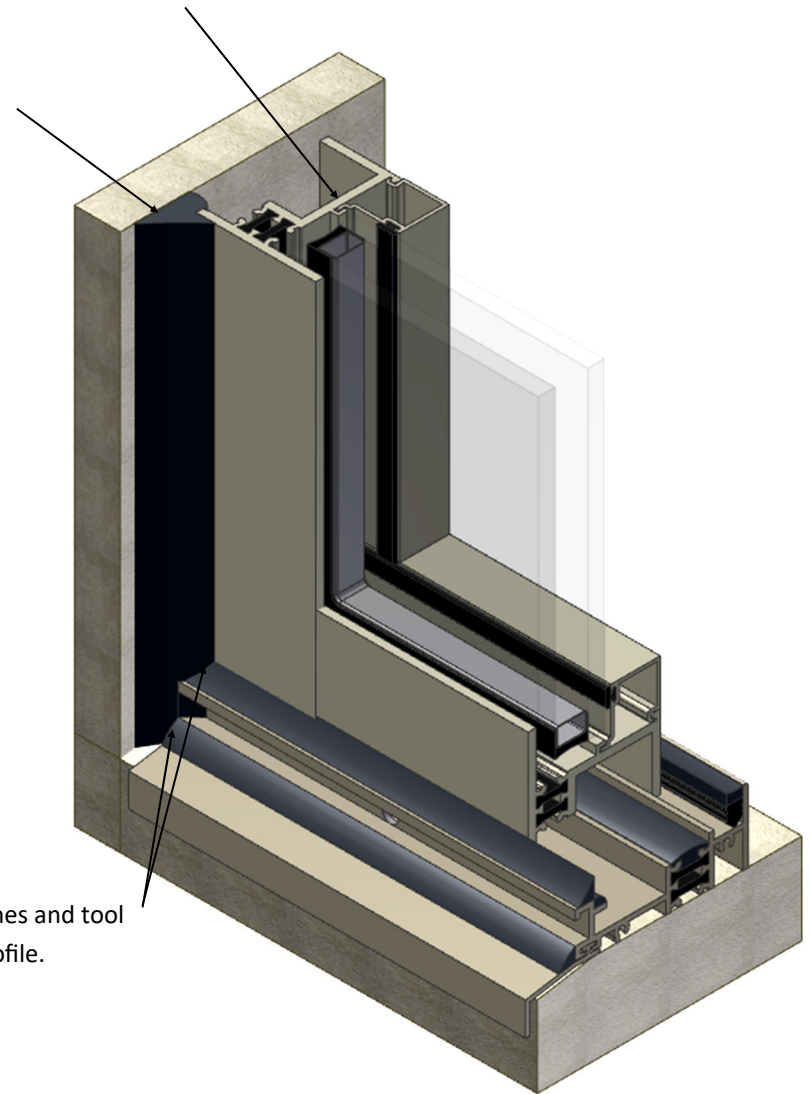

Window Installation Instructions - Typical Subframe Installation Section

3-Piece Mullion Installation Into Subframe:

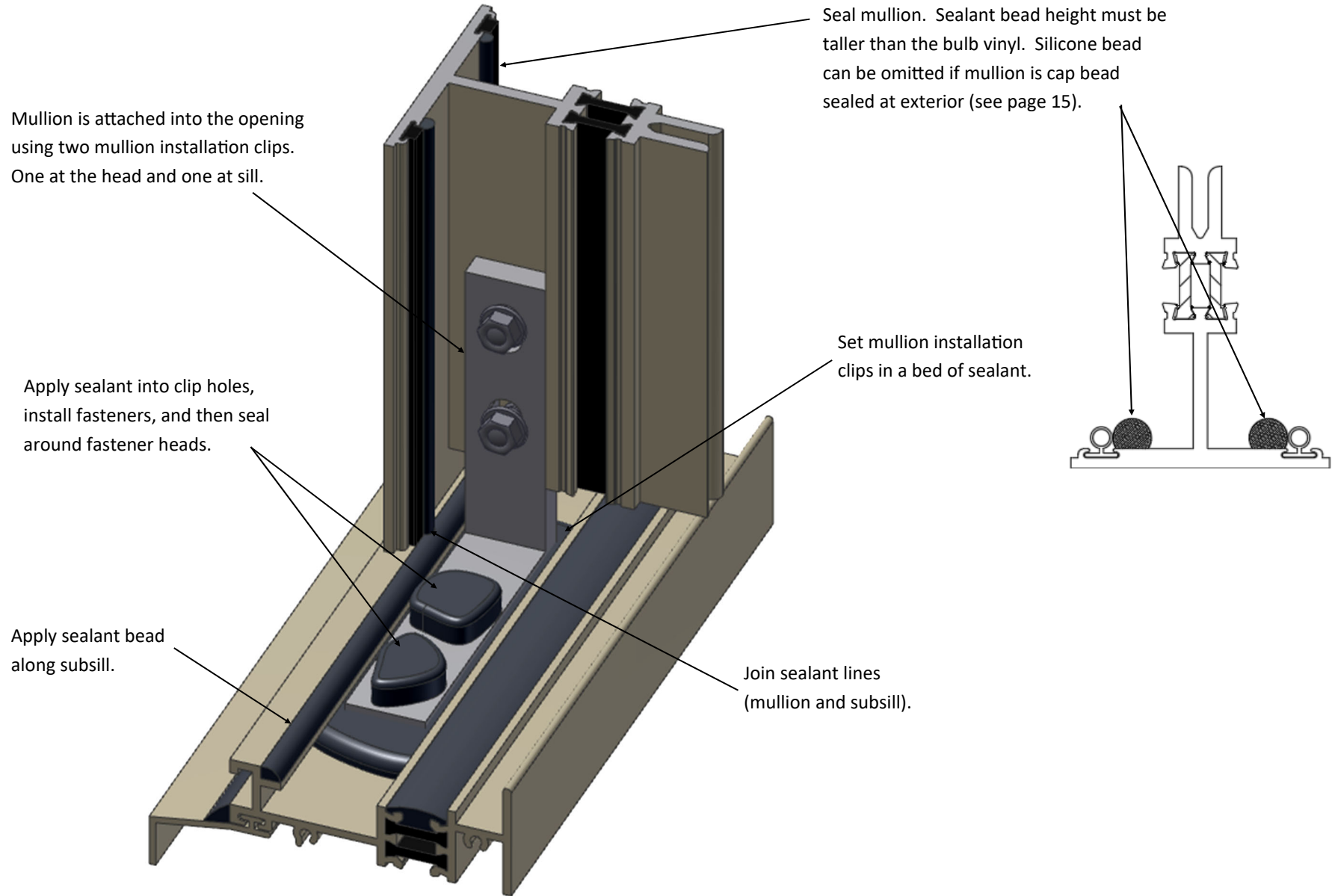

Window Installation Instructions - Typical Subframe Installation Section

3-Piece Mullion Installation Into Subframe (Continued):

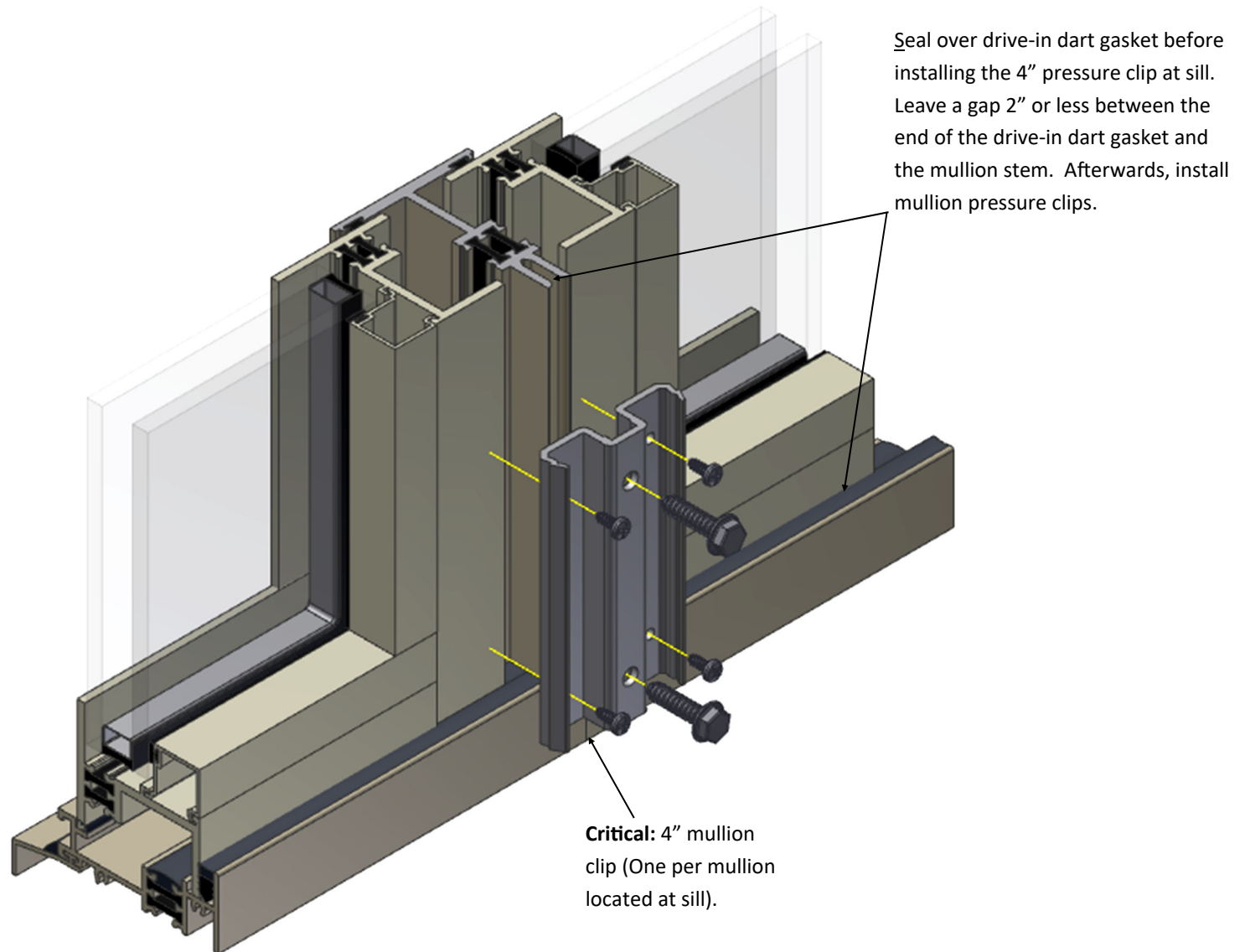

Note: Place first 1 1/4" long pressure clips as close to the subhead closure as possible. Other clips will be at 16" on center.

Window Installation Instructions - Typical Subframe Installation Section

Mullion Installation Into Subframe:

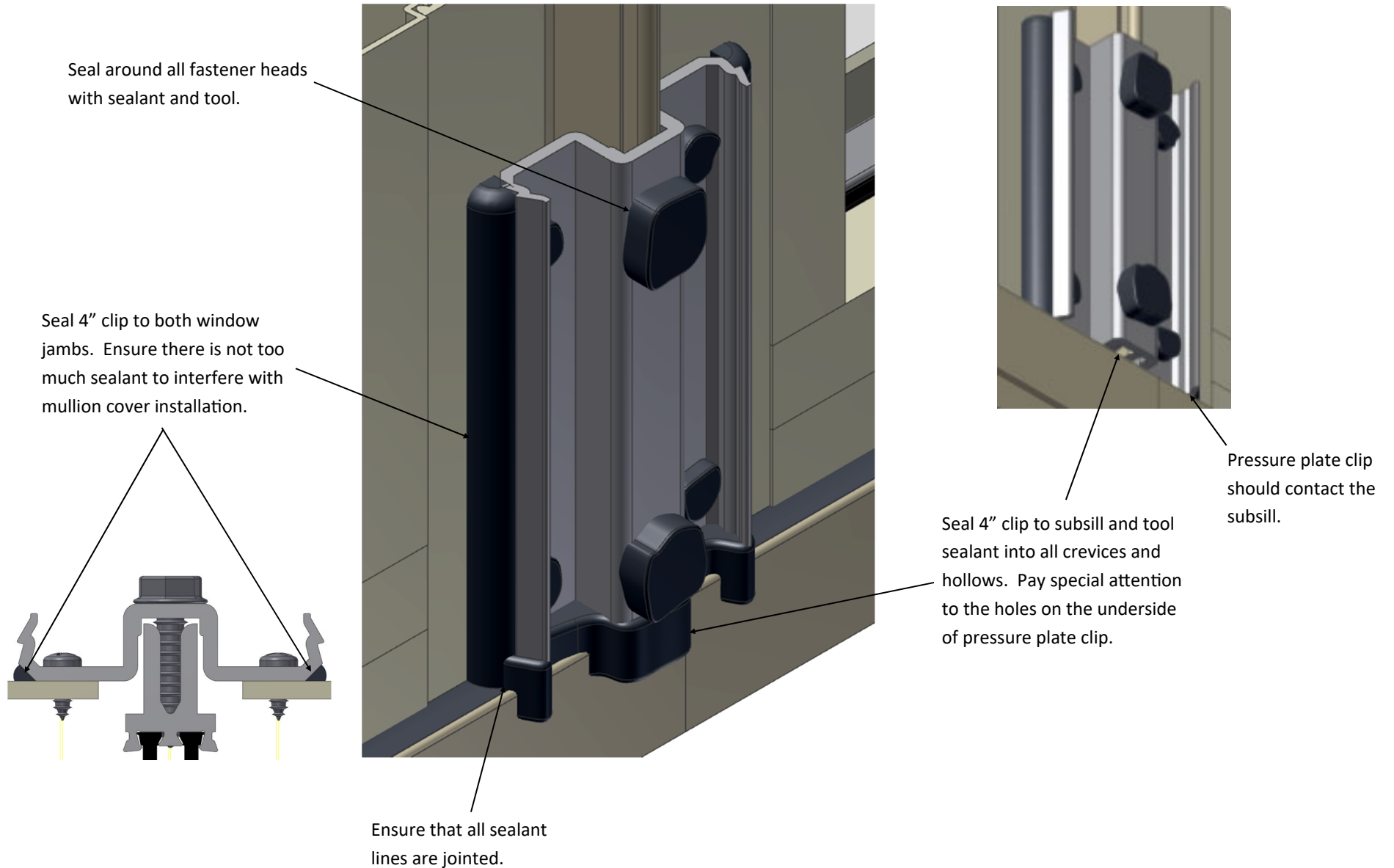

Window Installation Instructions - Typical Subframe Installation Section

Mullion Installation Into Subframe (Continued):

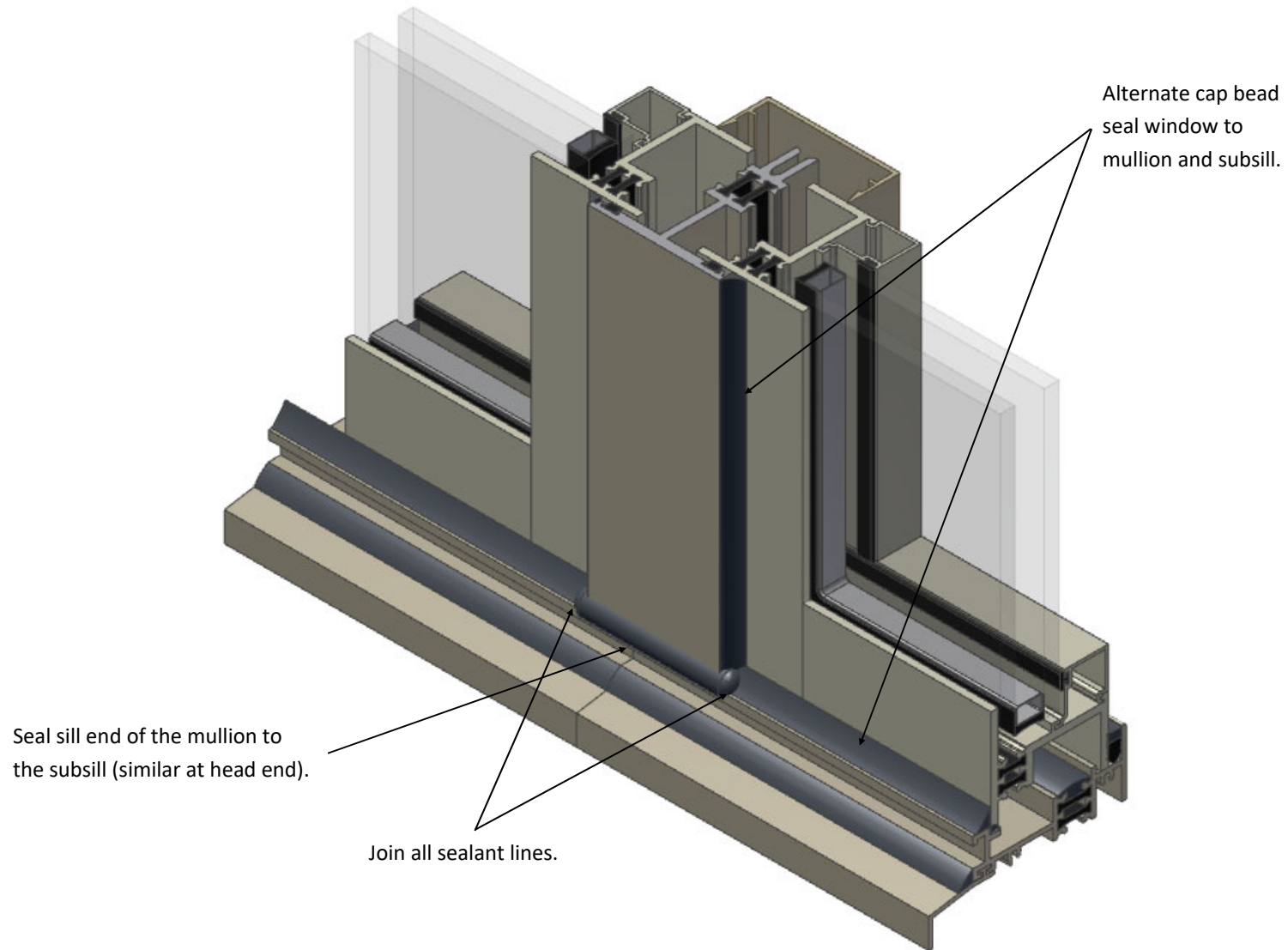

Window Installation Instructions - Typical Subframe Installation Section

Reversed Mullion Installation Into Subframe For Outside Set Window:

See page 14 for mullion installation clips and for sealant at mullion gasket reglet..

Note: Bead can be omitted if mullion cap is beaded at exterior (see next page).

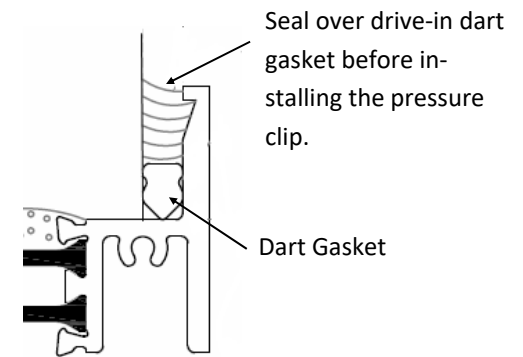
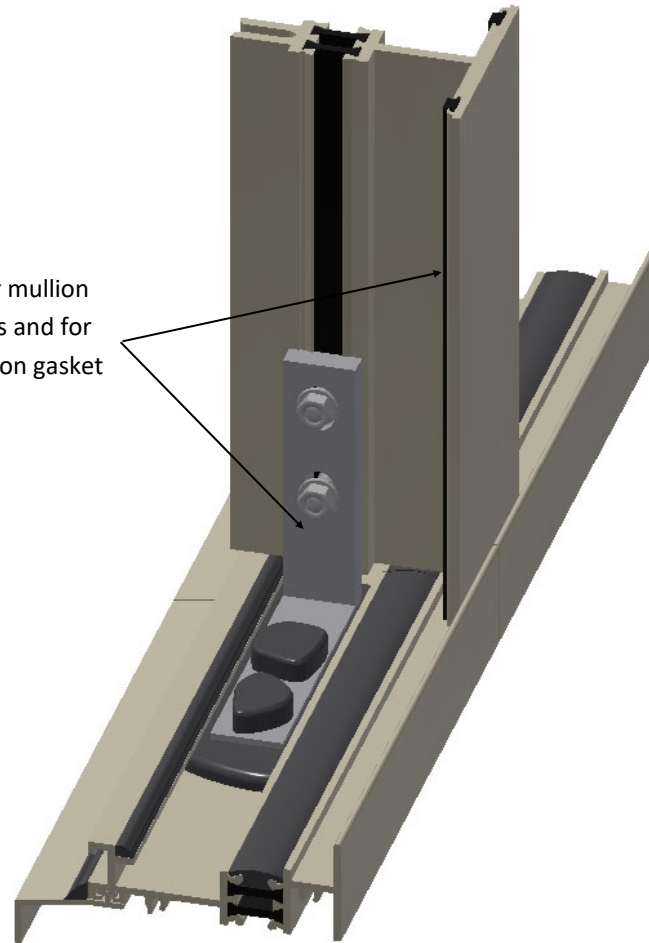
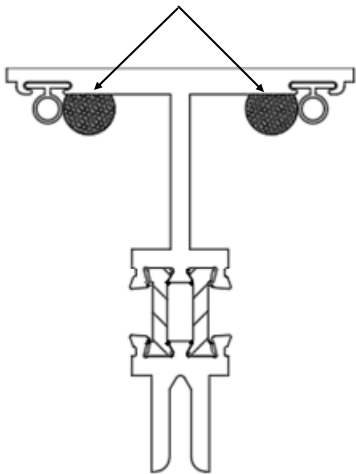

After the window, subhead closure, and subsill drive-in dart gaskets have been installed, install full length mullion pressure clips.

Window Installation Instructions - Typical Subframe Installation Section

Reversed Mullion Installation Into Subframe For Outside Set Window (Continued):

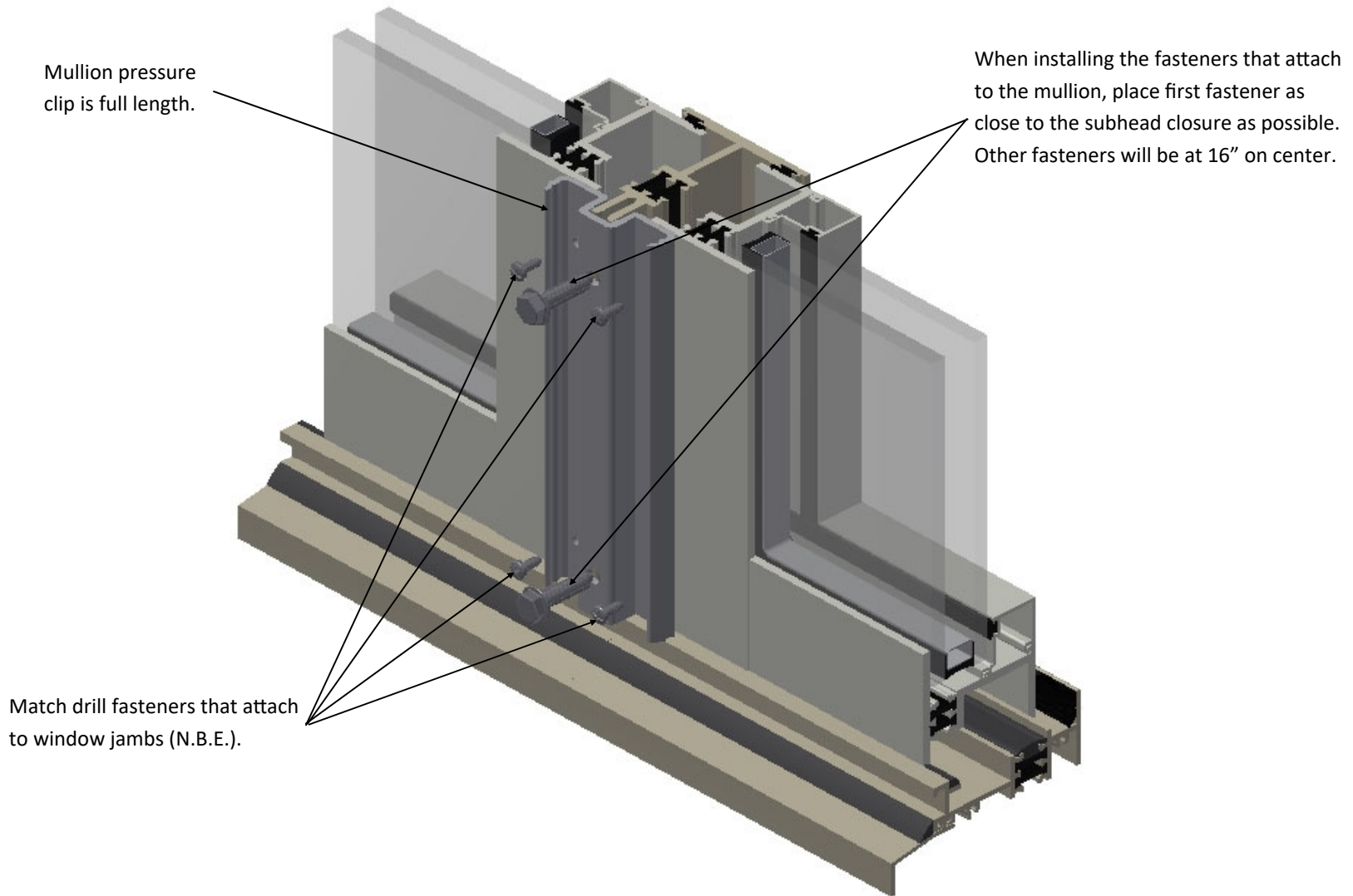

Note: If this method is used then the subjamb and subhead must be reversed.

Window Installation Instructions - Typical Subframe Installation Section

Reversed Mullion Installation Into Subframe For Outside Set Window (Continued):

Interior View of Subsill

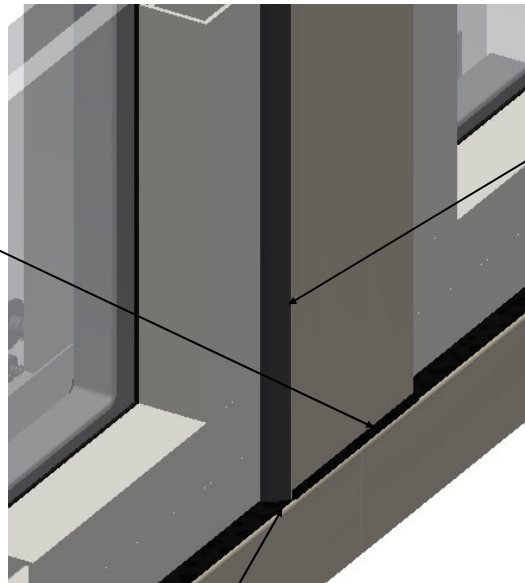

Butt seal end of mullion to subsill. Tool sealant into all crevices.

Seal mullion to both window jambs.

Note: If a bead of sealant was continuously placed next to gasket reglet of mullion (see previous page), then seal the mullion to both window jambs a minimum of 4". Otherwise, seal the full height of the mullion.

Ensure that all sealant lines are jointed.

Field cut and/or notch the mullion cover and snap over the mullion pressure clips.

Exterior View of Subsill

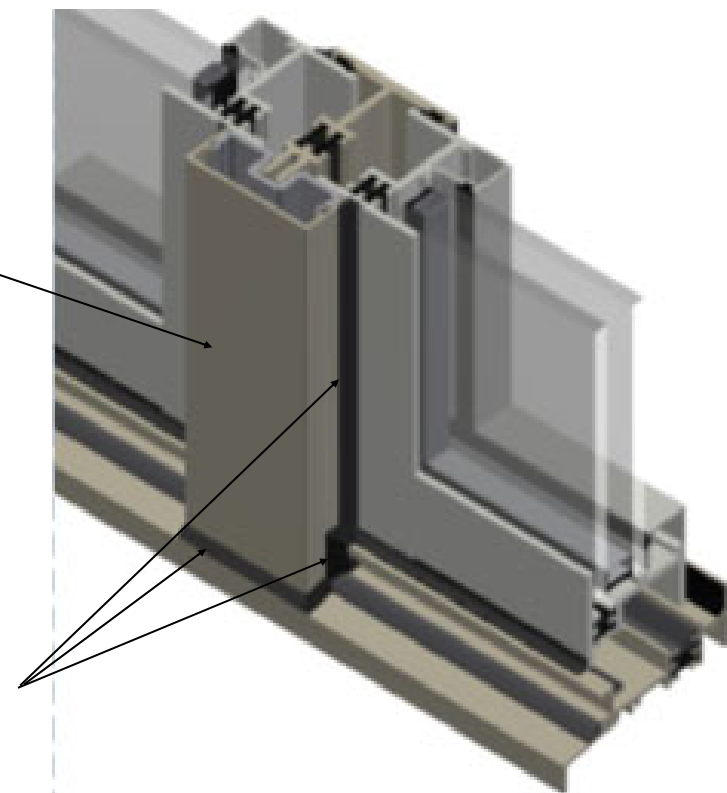

Seal the mullion cover to the subsill and both window jambs, and join all sealant lines.

Note: Seal similarly at head.

Completely read the General Installation Instructions and all other sections which pertain to your project before starting work. These recommendations are for general erection procedures only. For actual job conditions, see the details on the shop drawings. For perimeter anchor types and spacing, refer to the approved shop drawings or consult the project design professional.

General Installation Instructions for Subframes with Vapor Barriers

Subframe with vapor barrier legs, that is installed per these instructions, is designed to be fabricated to fit the exact window opening dimension.

Prep and installation, of the subframe, will follow the shop drawings and the typical sequence of the subframe installation instruction.

Subframe is either pre-fabricated at EFCO or sent in stick form for fabrication in the field. Fabrication needs, for this type of subframe, are to be determined before scheduling of the project.

The subframe components will have a mark designation that will tie the subframe to the window opening, if the subframe is specifically fabricated at EFCO.

1. Prepare and clean the face of the opening to accept a sealant with 50% movement. The vapor barrier legs must be fully sealed to the opening. Do not allow the face sealant to skim over before the installation of each subframe component.

INSTALLER NOTE:

The vapor barrier leg must overlap the bead of sealant. (Do not let the sealant skim over before the installation of each subframe component).



Completely read the General Installation Instructions and all other sections which pertain to your project before starting work. These recommendations are for general erection procedures only. For actual job conditions, see the details on the shop drawings. For perimeter anchor types and spacing, refer to the approved shop drawings or consult the project design professional.

2. Use silicone sealant to cover all of the subframe joints. Do not leave any holes, from the exterior side of the subframe joints, to the interior side. Sealant application is to follow the typical subframe installation instruction. Tool as necessary.



Application of the end dam sealant, to the subsill and condition, to follow typical subframe installation instructions.

(Do not let the sealant skim over before the installation of each subframe component.)

Application of the end dam sealant, to the subhead and condition, to follow typical subframe installation instructions.

(Do not let the sealant skim over before the installation of each subframe component.)



Completely read the General Installation Instructions and all other sections which pertain to your project before starting work. These recommendations are for general erection procedures only. For actual job conditions, see the details on the shop drawings. For perimeter anchor types and spacing, refer to the approved shop drawings or consult the project design professional.

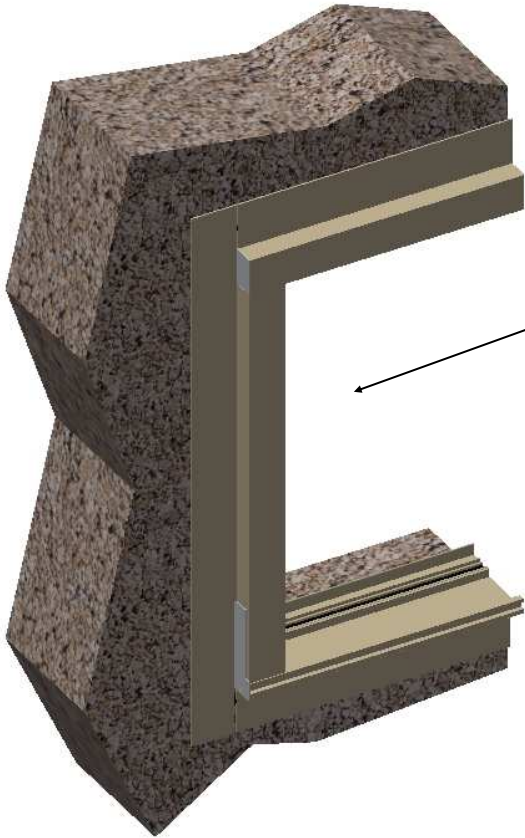

With the installation, of the subframe, all interior and exterior sealant lines may be applied per the typical subframe installation instructions.

(Do not let the sealant skim over before the installation of each subframe component.)

Apply sealant around the end dam and joints of the vapor barrier legs. Tool as necessary.

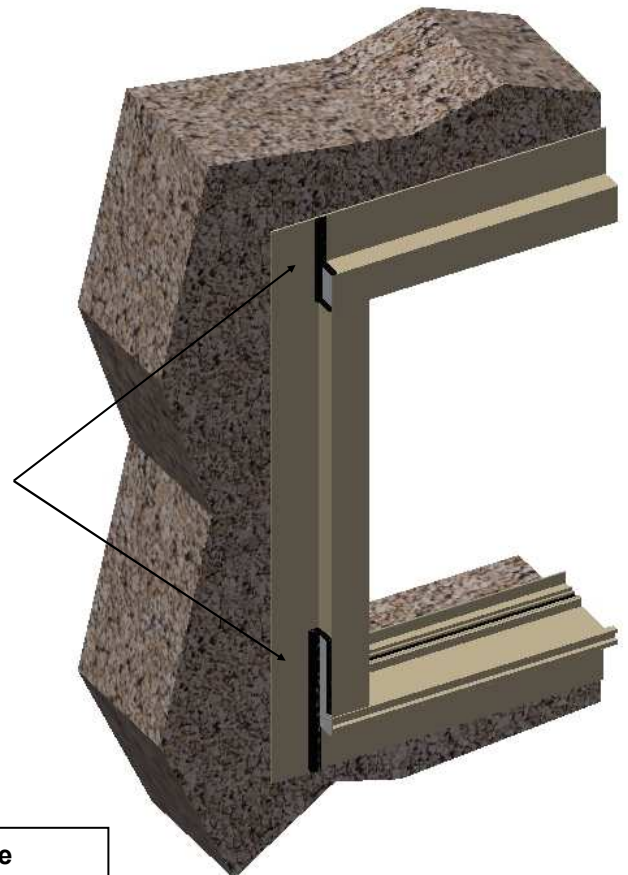

The application of a flashing tape may now be applied, to the building condition, overlapping the vapor barrier leg if required.

Completely read the General Installation Instructions and all other sections which pertain to your project before starting work. These recommendations are for general erection procedures only. For actual job conditions, see the details on the shop drawings. For perimeter anchor types and spacing, refer to the approved shop drawings or consult the project design professional.

Assembly fasteners that may be required for a pre-assembled subframe.

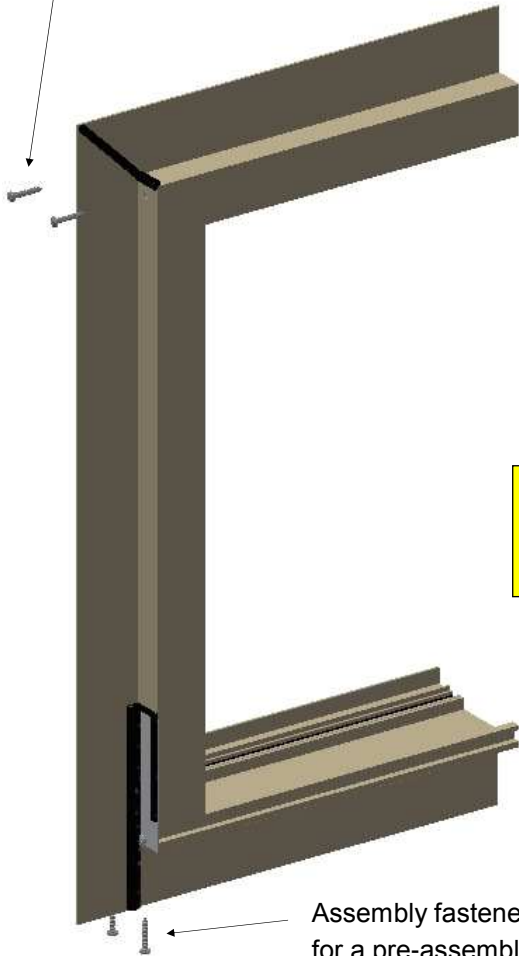

This page would be the typical illustration, for a pre-assembled subframe with vapor barrier legs, assembled before installation into the opening.

Sealant of the subframe to follow the typical subframe installation instruction.

These sealant lines may be applied before or after the pre-assembled subframe is installed into the opening. Please follow recommended sequence of application for the project.

Assembly fasteners that may be required for a pre-assembled subframe.

Apply sealant over the vapor barrier leg joint and screw heads. Tool as necessary.

Apply sealant over and around the end dam and joints of the vapor barrier legs and screw heads. Tool as necessary.

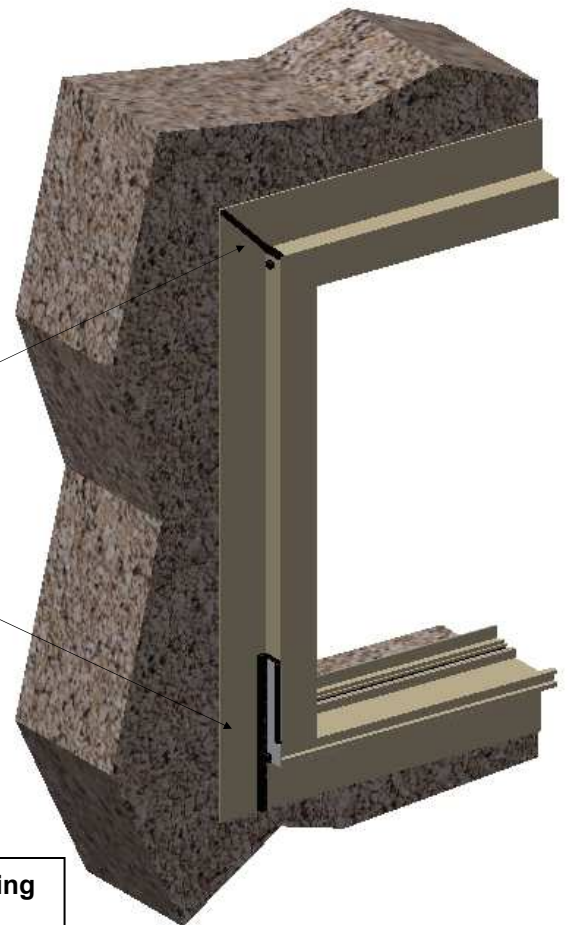

The application of a flashing tape may now be applied, to the building condition, overlapping the vapor barrier leg if required.

General Notes:

- These recommendations are for general erection procedures only.
- Completely read the General Installation Instructions and all other sections which pertain to your project before starting work.
- The following field installation instructions are best practice methods based on typical conditions, and must be used in conjunction with shop drawings.
- Some projects may require modifications to the standard procedure which must be coordinated with the shop drawings to maintain system performance.
- Cut the subsills, subjamb, subheads, and subhead closures to length and when they are installed, make sure they are all plumb, using shimming as necessary.
- Subframe that is to be pre-assembled before installation in the opening is designed to be fabricated to fit the exact window opening dimension.
- Prep and installation of the subframe will follow the shop drawings and the typical sequence of the subframe installation instructions.
- Subframe is either pre-fabricated at EFCO or sent in stick form for fabrication in the field, therefore, fabrication needs for this type of subframe are to be determined before scheduling of the project.
- Consult water proofing documents for requirements of setting flange in sealant.
- Do not allow sealant to skim before the installation of each subframe component.
- If required, the integral flange leg must overlap the bead of sealant.
- Prepare and clean the face of the opening to accept a sealant with 50% movement.
- The vapor barrier legs must be fully sealed to the opening.
- For perimeter anchor type and spacing, refer to the approved shop drawings or consult the project design professional. All anchorage clear holes, blocking, sealant, and perimeter fasteners are not by EFCO.
- For optimal water performance, ensure that all the subframing is installed level and true, and that all debris is removed from the subframing while installing.
- Seal around all fastener heads at sill with sealant to ensure water tight seal. Tool the sealant around the fastener heads so that the sealant makes contact with the surface of the subframe.

General Installation Instructions for Pre-Assembled Subframes with Vapor Barriers:

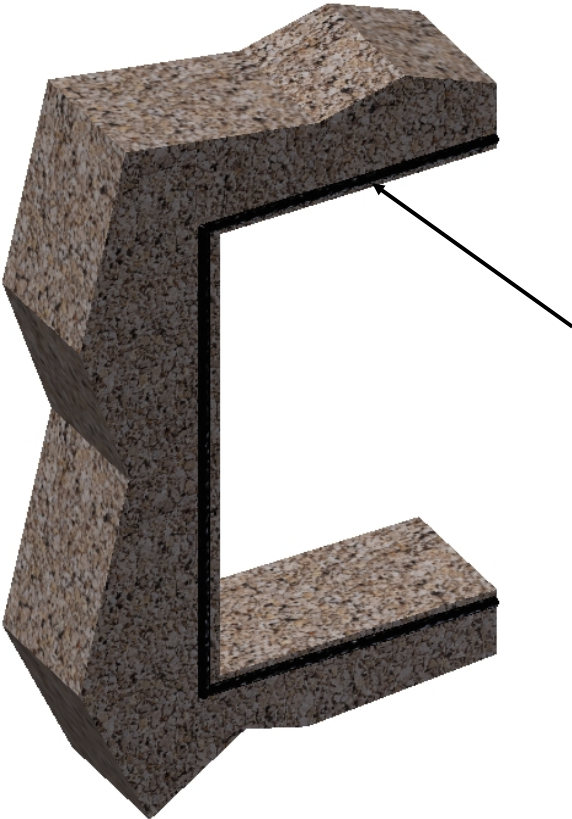

If required, the integral flange leg must overlap the bead of sealant. (Do not let the sealant skim over before the installation of each subframe component).

Note: This illustrates a typical pre-assembled subframe with an integral flange assembled before installation into the opening.

Assembly fasteners for mitered jamb to mitered head attachment.

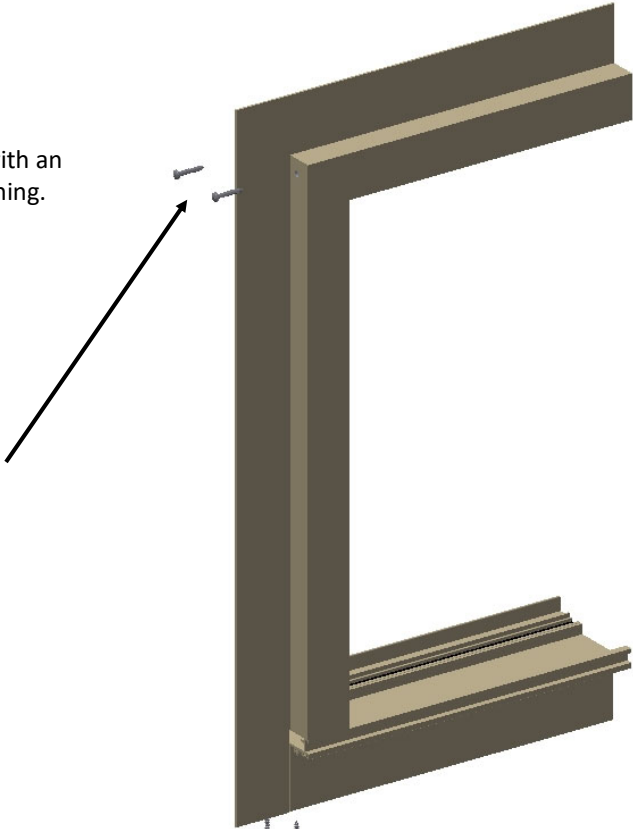

Assembly fasteners for coped jamb to sill attachment.

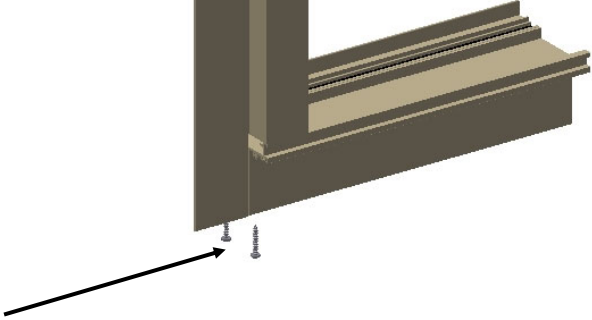

General Installation Instructions for Pre-Assembled Subframes with Vapor Barriers (Cont.):

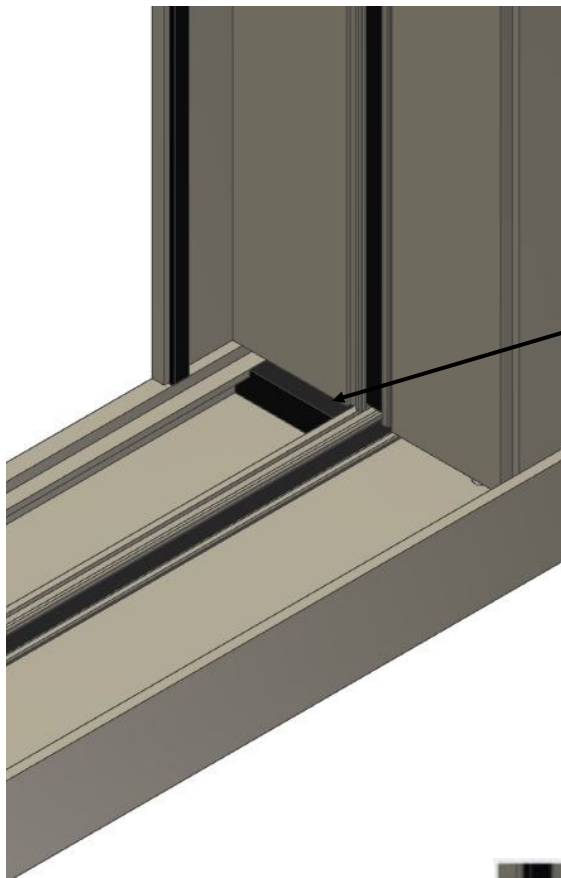

With the attachment of the subjamb, insert backer rod into the bottom cavity.

Apply sealant along the jamb to sill joint. Tool as necessary. Do not let the sealant skim over before the installation of each subframe component..

Seal subjamb leg to subsill and tool over joint at both exterior and interior.



General Installation Instructions for Pre-Assembled Subframes with Vapor Barriers (Cont.):

Note: The sealant lines may be applied before or after the pre-assembled subframe is installed into the opening. Please follow recommended sequence of application for the project.

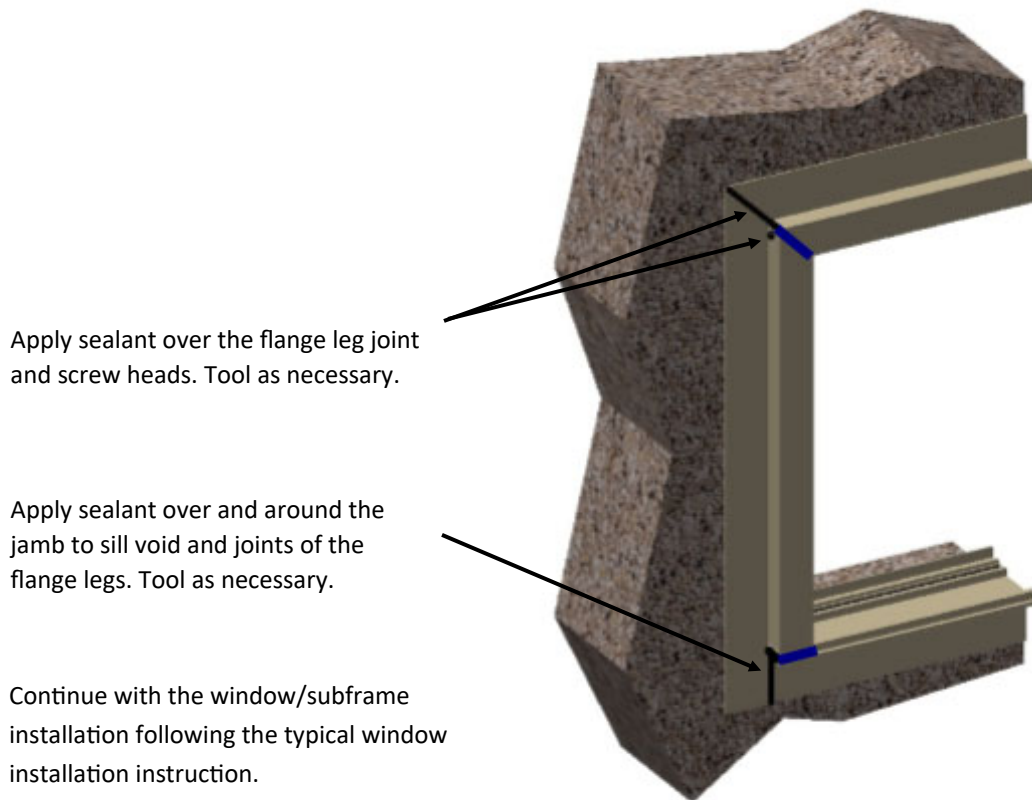

Note: The application of a flashing tape may now be applied to the building condition, overlapping the vapor barrier leg if required.

Completely read the General Installation Instructions and all other sections which pertain to your project before starting work. These recommendations are for general erection procedures only. For actual job conditions, see the details on the shop drawings. For perimeter anchor types and spacing, refer to the approved shop drawings or consult the project design professional.

General Installation Instructions for Window Screens

Project-In Screen Installation

1. Attach the screen clips to the window with short side of the angle towards D.L.O. (must be parallel with the frame).

NOTE: Clip screws are thread cutting fasteners. Thread cutting into the aluminum should be done with a screw wax or a silicone based lubricant to improve cutting action and reduce the required torque. If the screen clips are being reapplied, no lubricant on the screw is required, and the screws should be started by hand or a hand driver should be used to prevent cross threading.

2. Pass the screen through the window opening.
3. Hang on to the slide pins and pull the screen toward the window.
4. Lower the slide pins in to the screen clips.
5. Release after the pins are seated, and press the pins down to snug to the frame.

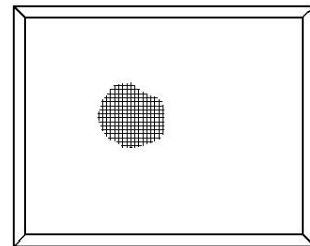

Typical elevation viewed from exterior

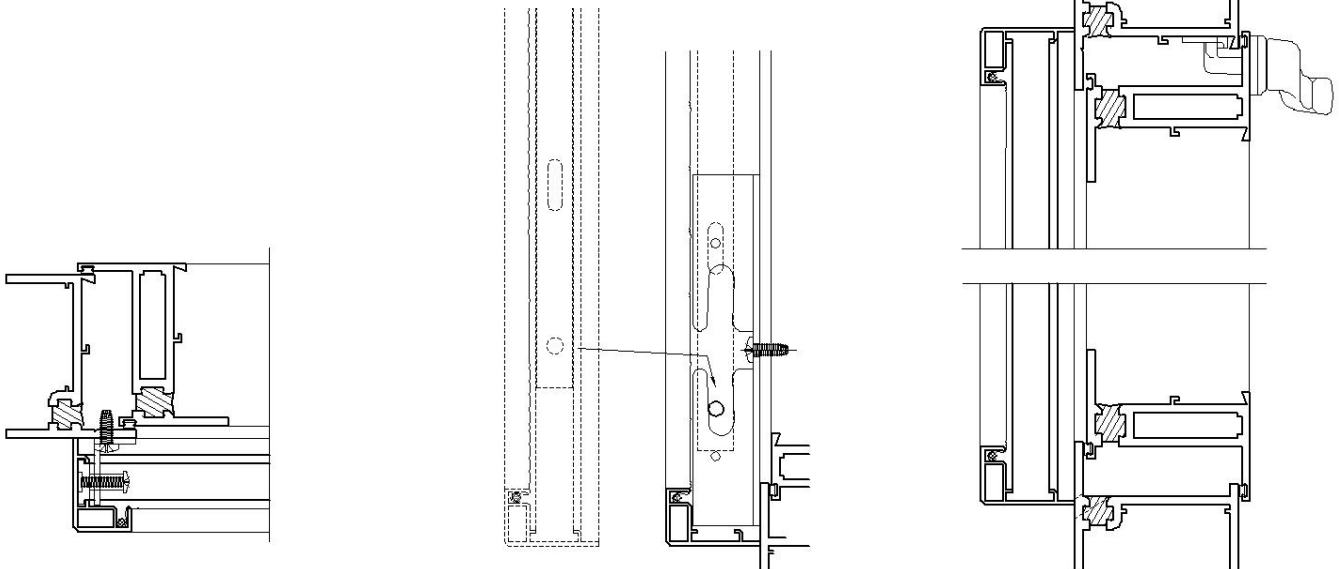

Completely read the General Installation Instructions and all other sections which pertain to your project before starting work. These recommendations are for general erection procedures only. For actual job conditions, see the details on the shop drawings. For perimeter anchor types and spacing, refer to the approved shop drawings or consult the project design professional.

Project-Out Screen Installation

1. Attach the screen clips to the window with short side of the angle towards D.L.O. (must be parallel with the frame).

NOTE: Clip screws are thread cutting fasteners. Thread cutting into the aluminum should be done with a screw wax or a silicone based lubricant to improve cutting action and reduce the required torque. If the screen clips are being reapplied, no lubricant on the screw is required, and the screws should be started by hand or a hand driver should be used to prevent cross threading.

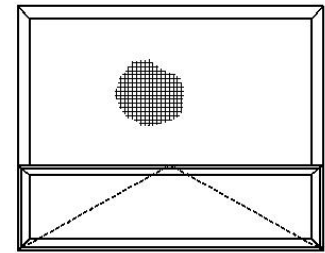

Typical Elevation
Viewed From Interior

2. Open the wicket.
3. Hang on to the slide pins and push the screen toward the window.
4. Lower the slide pins in to the screen clips.
5. Release after the pins are seated, and press the pins down to snug to the frame.

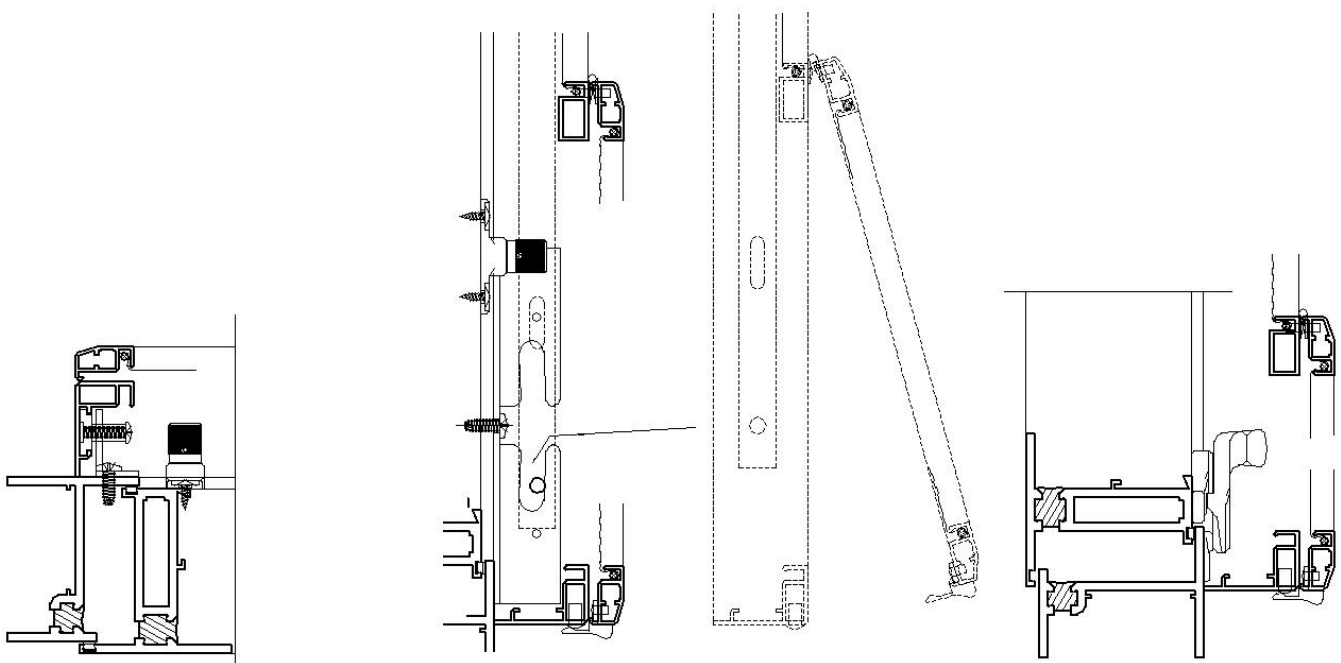
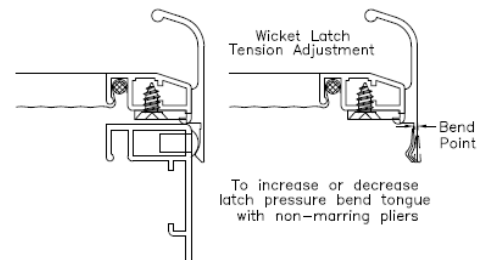

Completely read the General Installation Instructions and all other sections which pertain to your project before starting work. These recommendations are for general erection procedures only. For actual job conditions, see the details on the shop drawings. For perimeter anchor types and spacing, refer to the approved shop drawings or consult the project design professional.

Project-Out Casement Screen Installation

1. Attach the screen clips to the window with short side of the angle towards D.L.O. (must be parallel with the frame).

NOTE: Clip screws are thread cutting fasteners. Thread cutting into the aluminum should be done with a screw wax or a silicone based lubricant to improve cutting action and reduce the required torque. If the screen clips are being reapplied, no lubricant on the screw is required, and the screws should be started by hand or a hand driver should be used to prevent cross threading.

2. Open the wicket.
3. Hang on to the slide pins and push the screen toward the window.
4. Lower the slide pins in to the screen clips.
5. Release after the pins are seated, and press the pins down to snug to the frame.

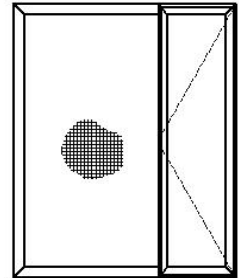

Typical Elevation Viewed From Interior

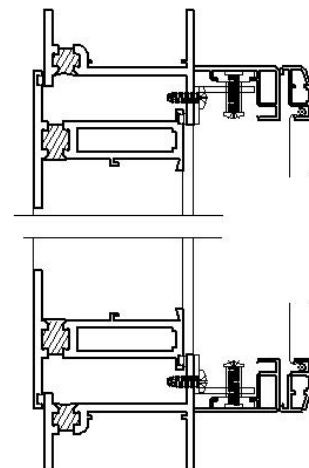
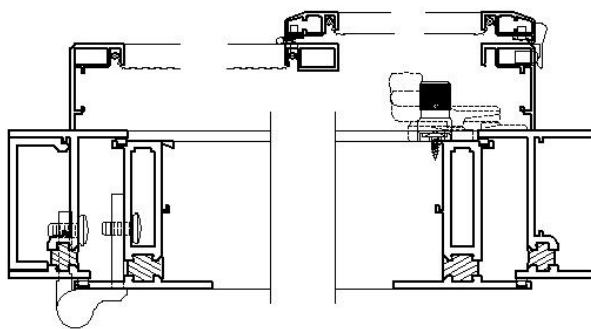
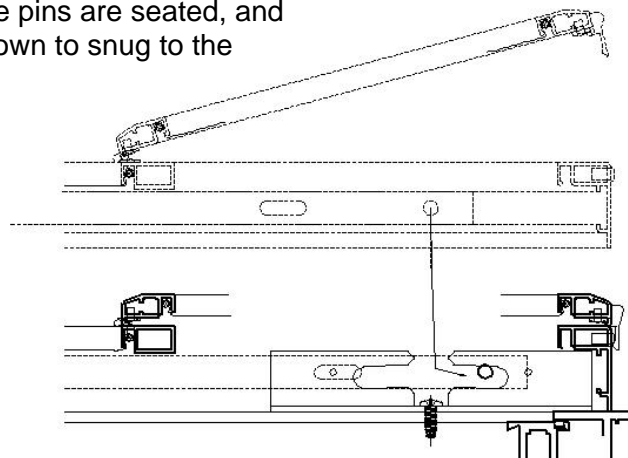
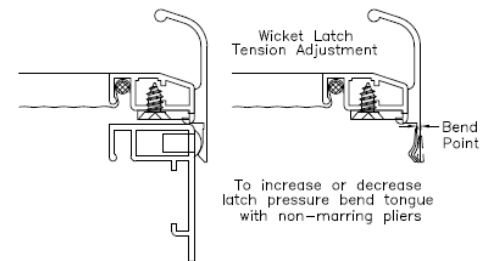

Completely read the General Installation Instructions and all other sections which pertain to your project before starting work. These recommendations are for general erection procedures only. For actual job conditions, see the details on the shop drawings. For perimeter anchor types and spacing, refer to the approved shop drawings or consult the project design professional.

Single Hung With Half Screen Installation

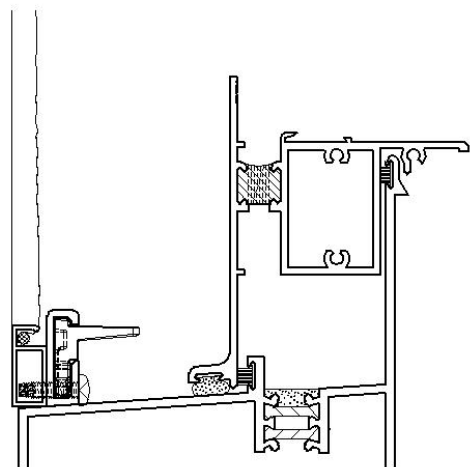
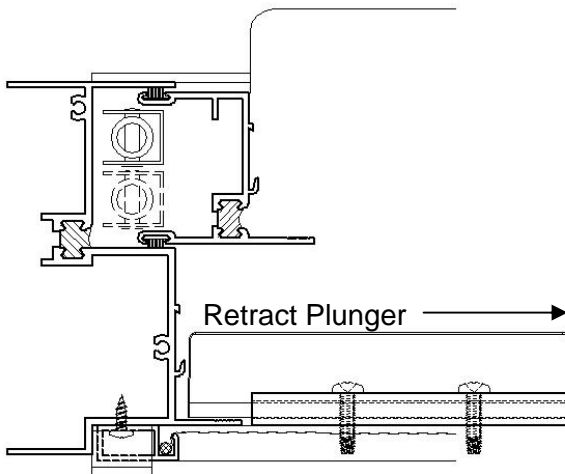
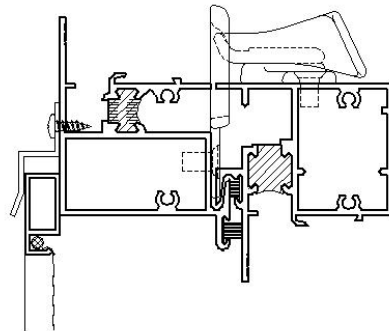
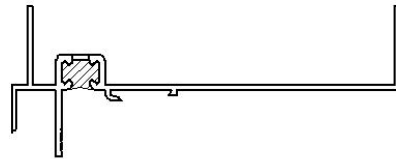
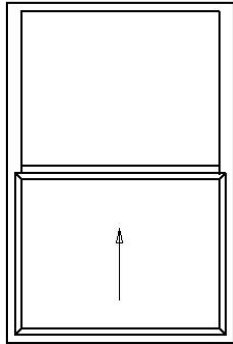

Completely read the General Installation Instructions and all other sections which pertain to your project before starting work. These recommendations are for general erection procedures only. For actual job conditions, see the details on the shop drawings. For perimeter anchor types and spacing, refer to the approved shop drawings or consult the project design professional.

Double Hung With Full Screen Installation

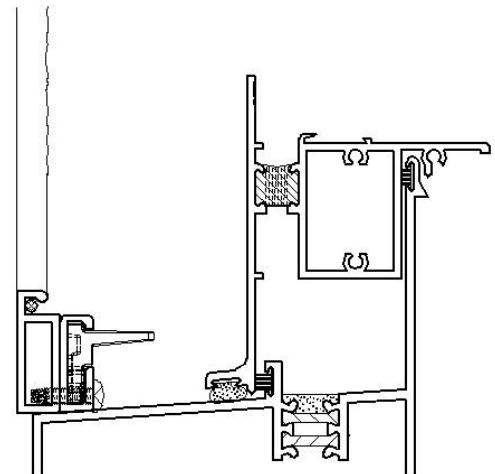
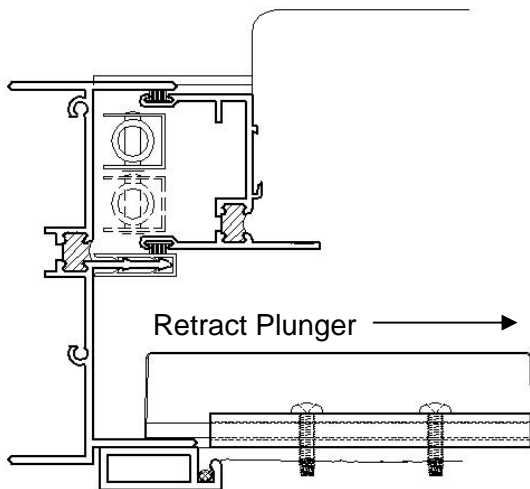
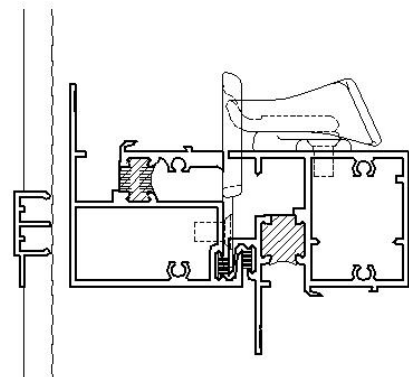
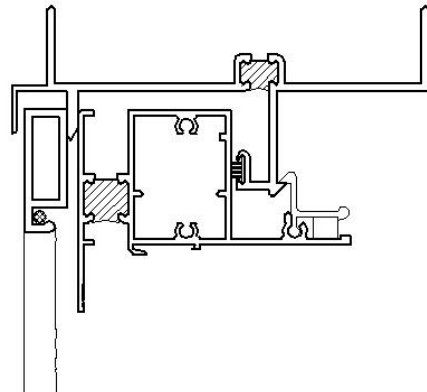
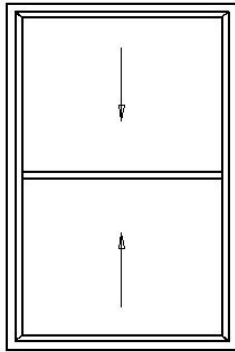

Completely read the General Installation Instructions and all other sections which pertain to your project before starting work. These recommendations are for general erection procedures only. For actual job conditions, see the details on the shop drawings. For perimeter anchor types and spacing, refer to the approved shop drawings or consult the project design professional.

Sliding Window Screen Installation

1. To remove the screen, push the screen toward the jamb compressing the spring. Swing the screen outward at the meeting rail side.

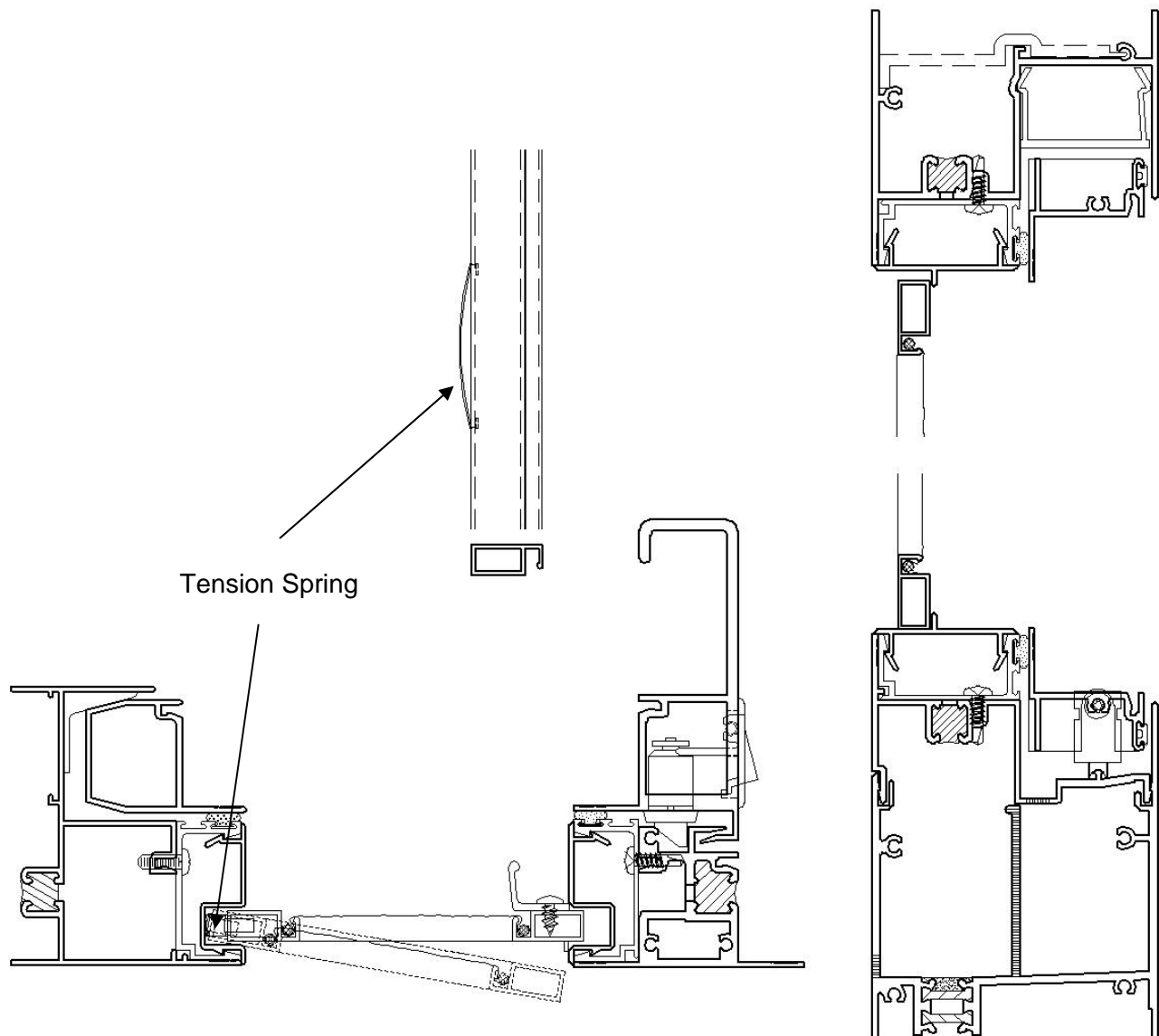
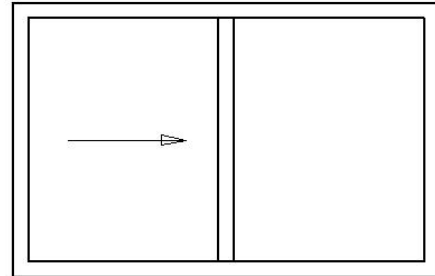

INTERIOR VERTICAL SLIDING SCREEN INSTALLATION

THIS SHEET IS FOR GENERAL RECOMMENDED ERECTION PROCEDURES ONLY. FOR ACTUAL JOB CONDITIONS, SEE THE DETAILS ON THE SHOP DRAWINGS (IF APPLICABLE).

1) INSTALL THE HEAD AND SILL INTERIOR TRIM CLIPS. START BY ATTACHING THE FIRST CLIP APPROXIMATELY 6" FROM EACH CORNER, THEN EVERY 16" O.C.. ATTACH THE CLIPS TO THE WINDOW WITH EFCO'S STT6 SCREWS AND TO THE OPENING WITH THE ERECTOR FURNISHED ANCHORS. HOLE DRILLING IN CLIPS IS NOT BY EFCO. THE TRIM CLIPS PROVIDE THE STRUCTURAL SUPPORT FOR THE WINDOW UNIT. EACH CLIP MUST BE ATTACHED TO BOTH THE WINDOW AND THE OPENING TO SECURE THE WINDOW IN THE OPENING.

2) ALL INTERIOR TRIM COVERS ARE TO BE CUT TO SIZE IN THE FIELD. HORIZONTAL INTERIOR TRIM COVERS ALWAYS RUN THROUGH AND MUST BE INSTALLED FIRST. TO INSTALL, MEASURE THE INTERIOR HORIZONTAL OPENING WIDTH AND CUT THE HORIZONTAL TRIM COVERS ACCORDINGLY, THEN SNAP IN PLACE.

3) INSTALLING THE JAMB INTERIOR TRIM CLIPS REQUIRES A SIMILAR METHOD OF ATTACHMENT AS NOTED IN STEP ONE. THE EXCEPTION IS THAT THE ALIGNMENT TAB ON THE JAMB CLIPS MUST BE TIGHT AGAINST THE WINDOW LEG TO ENSURE THE CORRECT WICKET SIZE WITH PARALLEL TRACKS. OPENING SIZE ADJUSTMENTS MUST BE MADE BY SHIMMING BETWEEN THE CLIP AND THE EXISTING OPENING RATHER THAN CHANGING THE CLIP TO WINDOW FRAME OVERLAP. (SEE FIG. BELOW)

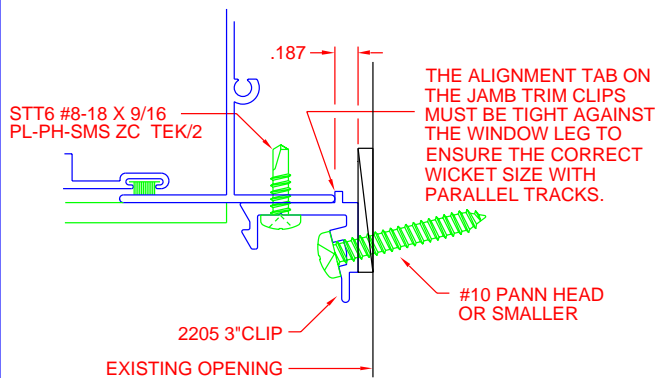

4) MEASURE BETWEEN THE HORIZONTAL TRIM COVERS, THEN CUT THE VERTICAL TRIM COVERS TO THE PROPER LENGTH. SNAP THE VERTICAL TRIM COVERS INTO PLACE.

5) ATTACH SHEAR BLOCKS FOR MOUNTING THE HORIZONTAL SCREEN MEETING RAIL WITH STT6 TEK SCREW. THE SHEAR BLOCK SHOULD BE LOCATED .062 BELOW THE SCREEN TOP RAIL IF THE SCREEN WAS SITTING ON TOP OF THE SILL TRIM. (SEE FIG. BELOW.)

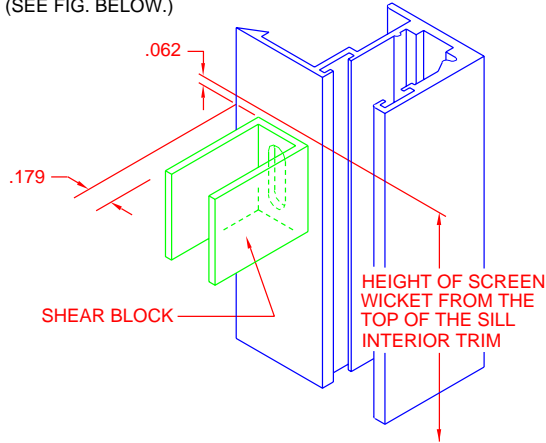

6) LOWER THE SCREEN MEETING RAIL OVER THE SHEAR BLOCKS WITH THE SHORTER WEATHERSTRIP AND ATTACHMENT HOLE ON THE ROOM SIDE. CARE MUST BE TAKEN NOT TO SCRATCH THE JAMB TRIM. SOME FIELD ADJUSTMENTS MAY BE REQUIRED TO THE SCREEN MEETING RAIL LENGTH, TO FACILITATE INSTALLATION. FASTEN THE MEETING RAIL TO THE SHEAR BLOCK WITH ONE SFZ5 SCREW IN EACH END. HOLE DRILLING IN THE SHEAR BLOCK FOR THE SFZ5 IS NOT BY EFCO.

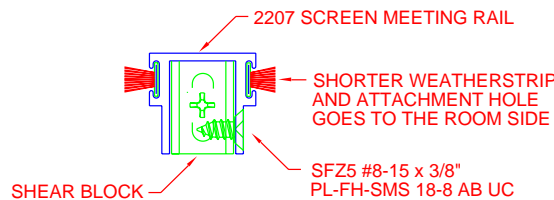

7) PRESS THE LOWER TRIM FILLER VINYL INTO THE SCREEN TRACK ON BOTH SIDES. THE LOWER TRIM FILLER WILL HAVE A 9/16\"/>

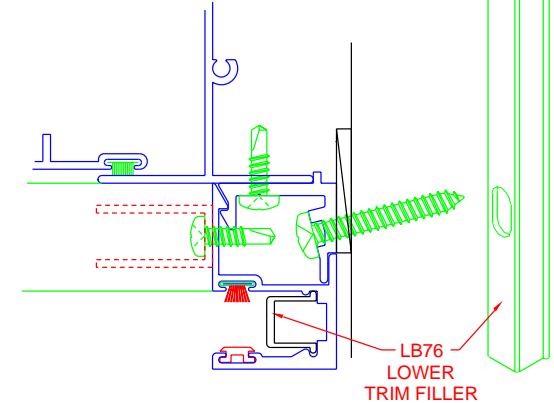

8) THE UPPER TRIM FILLERS ARE SENT LONG TO BE CUT TO SIZE IN THE FIELD. MEASURE THE REMAINING TRACK LENGTH FROM THE TOP OF THE LOWER TRIM FILLER TO THE UNDERSIDE OF THE HEAD TRIM, THEN CALCULATE THE FILLER CUT LENGTH 1/8\"/>

9) INSTALL ONLY ONE OF THE UPPER TRIM FILLERS AT THIS TIME. WITH THE SCREEN HANDLE RAIL AT THE BOTTOM AND THE PLUNGERS FACING THE ROOM, SIDE LOAD THE SCREEN INTO THE EMPTY UPPER JAMB TRACK. RETRACT BOTH PLUNGERS AND LOWER THE SCREEN TO THE BOTTOM OF THE TRACKS. INSTALL THE OTHER UPPER TRIM FILLER BY SLIDING IT INTO THE SCREEN TRACK BEHIND THE UPPER END OF THE SCREEN. ABOUT 1/2\"/>